

**Series: ROOF TOP UNIT TYPE 40 , flat**  
 with FISCHBACH COMPACT FAN  
 Type CE with forward curved blades

**FISCHBACH**  
 Luft- und Ventilatorentechnik GmbH

EC-MOTOR  
 EC-MOTEUR

**Type: 40-2-EC CE5-670/EM15**

ERP KONFORM

CE -conform

UK  
 CA



**manufacturer:**  
 Fischbach Luft- und Ventilatorentechnik GmbH  
 Am Hellerberg 22-24  
 D-57290 Neunkirchen  
 phone: ++49(0)2735/777-0  
 telefax: ++49(0)2735/770-133  
 internet: www.fischbach-luft.de  
 email: info@fischbach-luft.de

**Technical Data**

weight:	(kg)	36
material housing:	steel, galvanized	
material impeller:	steel, galvanized	
direction of rotation:	left	
motor protection class:	IP 65	
insulation class:	F	
motor protection:	thermal contact	

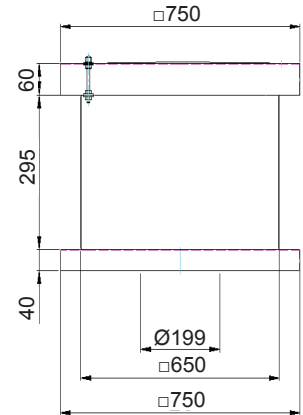
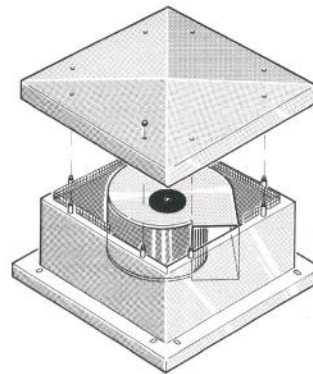

connection plan \*  
 F-EC 0.5

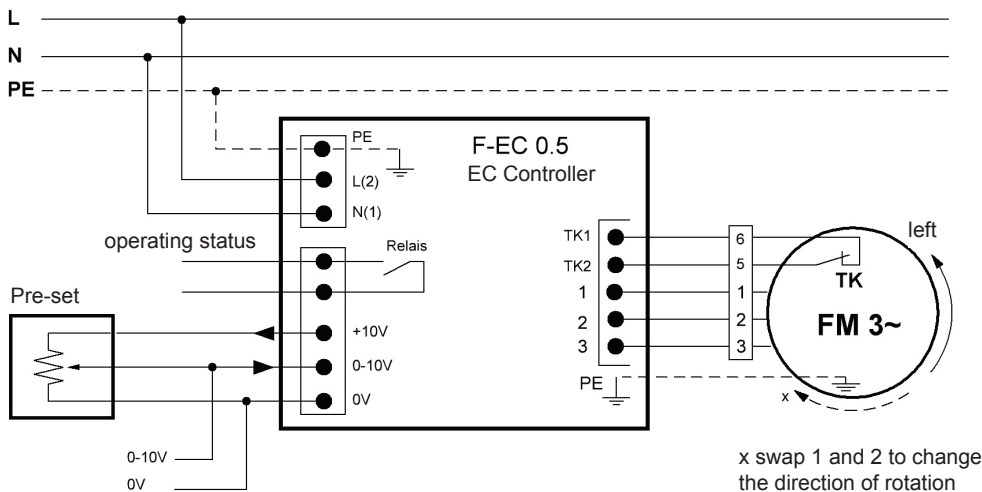

\* Connection only according to the enclosed technical documentation.

the silent one



**Series: ROOF TOP UNIT TYPE 40 , flat**  
 with FISCHBACH COMPACT FAN  
 Type CE with forward curved blades

**FISCHBACH**

Luft- und Ventilatorentechnik GmbH

EC-MOTOR  
 EC-MOTEUR

**Type: 40-2-EC CE5-670/EM15**

Erp 2013 2015 2018 x

**Performance data**

main voltage:	(V)	230 (1~)
frequency:	(Hz)	50
current max.:	(A)	4,1
power input max.:	(kW)	0,59
air flow volume max.:	(m³/h)	2299
statical pressure max.:	(Pa)	515
speed max.:	(rpm)	1568
supply air temperature:	(°C)	-20... +50
capacitor:	(µF)	-

**ErP-Data:**

total efficiency fan ( $\eta_e$ ):	(%)	44,2
installation category:		A
efficiency category:		static
efficiency grade: N	(%)	42
target efficiency ( $\eta_{target}$ ):	(%)	34,9
speed controller		yes
year of manufacturing		since 2015
manufacturer:	Fischbach Luft- und Ventilatorentechnik GmbH D-57290 Neunkirchen / HRB 5804 Siegen	
order no.		58040019
power input:	(kW)	0,32
air flow volume:	(m³/h)	1075
statical pressure:	(Pa)	422
speed:	(rpm)	1436
specific ratio:		1

disassembling/recycling/disposal: see page decommission  
 installation/operation/maintenance: see operating and mounting instructions  
 measurement for determination of efficiency without additional items

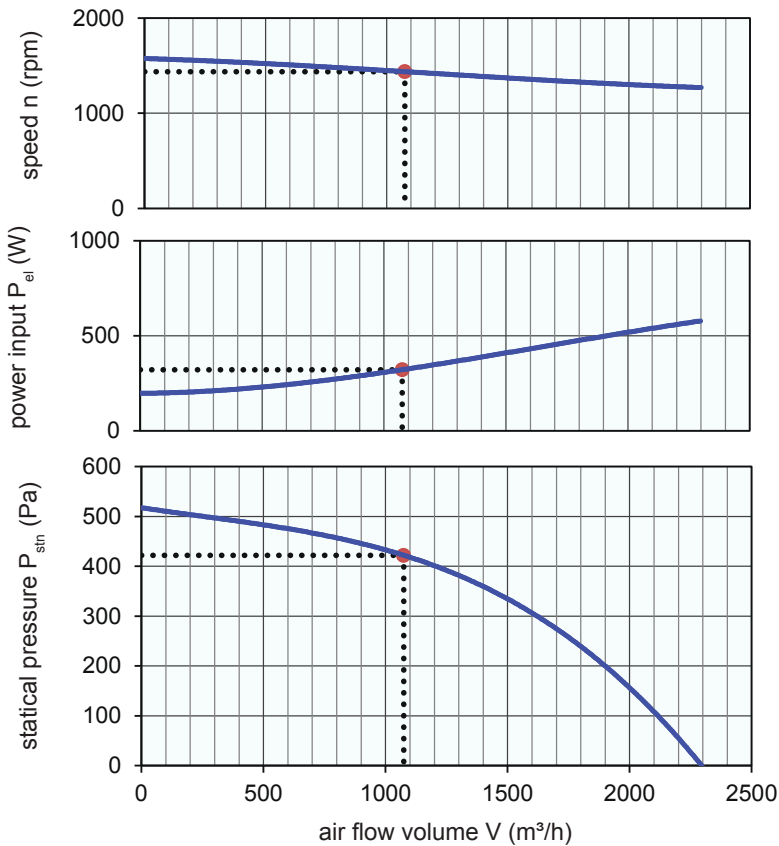

**EC-controller included / accessories / sound data**, please see in the appropriate table

Technical documentation according to page: **General information**