

Series: THERMAL-EXHAUST-UNIT FMBT-EC
 with Freewheeling impeller with
 backward curved blades **EC-MOTOR**

FISCHBACH
 Luft- und Ventilatorentechnik GmbH

Type: FMBT-EC-40/400/EM35

ERP KONFORM



manufacturer:

Fischbach Luft- und Ventilatorentechnik GmbH
 Am Hellerberg 22-24
 D-57290 Neunkirchen
 phone:
 telefax:
 internet:
 email:

++49(0)2735/777-0
 ++49(0)2735/770-133
 www.fischbach-luft.de
 info@fischbach-luft.de

Technical Data

weight:	(kg)	30
material housing:	aluminum/plastic steel, galvanized	
material impeller:	steel, galvanized	
direction of rotation:	left/right	
motor-protection class:	IP 65	
insulation class:	F	
motor protection:	thermal contact	

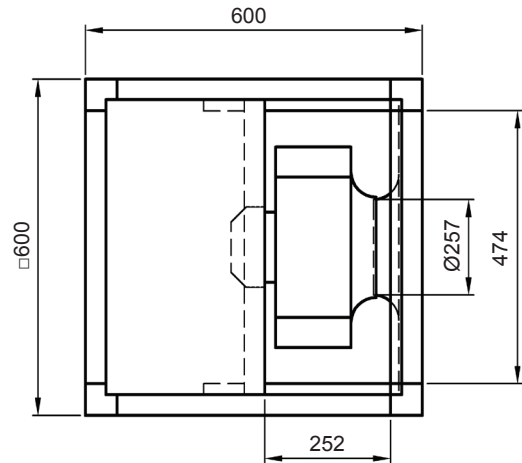

**connection plan*
 FFU-EC 230**

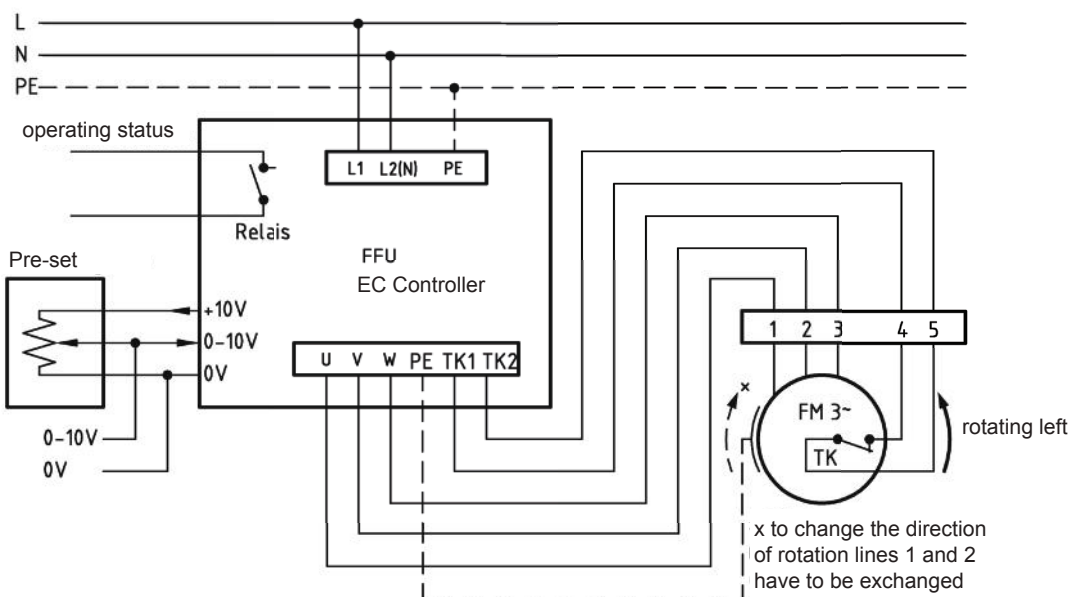

* Connection only according to the enclosed technical documentation.

the silent one

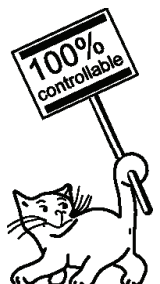

Series: THERMAL-EXHAUST-UNIT FMBT-EC

with Freewheeling impeller with
backward curved blades **EC-MOTOR**

FISCHBACH

Luft- und Ventilatorentechnik GmbH

Type: FMBT-EC-40/400/EM35

Erp 2013 2015 2018 x

Performance data

main voltage:	(V)	230 (1~)
frequency:	(Hz)	50
current max.:	(A)	4,1
power input max.:	(kW)	0,64
air flow volume max.:	(m³/h)	4600
statical pressure max.:	(Pa)	543
speed max.:	(rpm)	1500
max. air flow temperature	(°C)	+80
max. ambient temperature	(°C)	+30
capacitor:	(µF)	-

ErP-Data:

total efficiency fan (η_e):	(%)	55,9
installation category:		A
efficiency category:		static
efficiency grade: N	(%)	62
target efficiency (η_{target}):	(%)	49,3
speed controller		yes
year of manufacturing		since 2015
manufacturer:	Fischbach Luft- und Ventilatorentechnik GmbH D-57290 Neunkirchen / HRB 5804 Siegen	
order no.		
power input:	(kW)	0,62
air flow volume:	(m³/h)	2505
statical pressure:	(Pa)	452
speed:	(rpm)	1500
specific ratio:		1
disassembling/recycling/disposal:	see page decommission	
installation/operation/maintenance:	see operating and mounting instructions	
measurement for determination of efficiency without additional items		

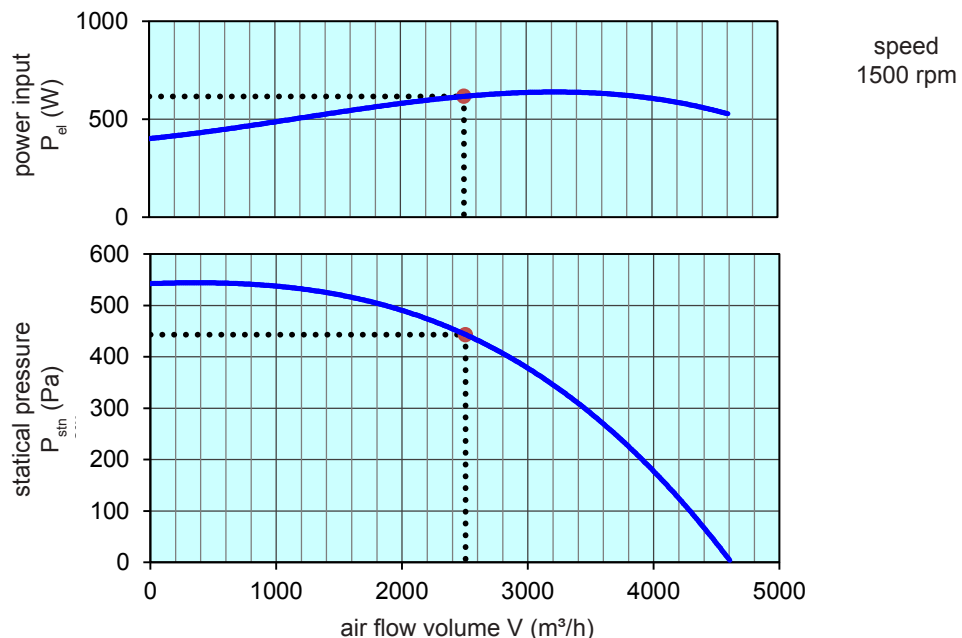

control with	type	order-Nr.
FISCHBACH-EC-controller	FFU1-21-2.2	63720
FISCHBACH-Pre-set 0-10V (optional accessories)	FS 10	69460

Technical documentation according to page: **General information**