

Wiring diagram - AP-EC1.05 EC controller F-EC0.5

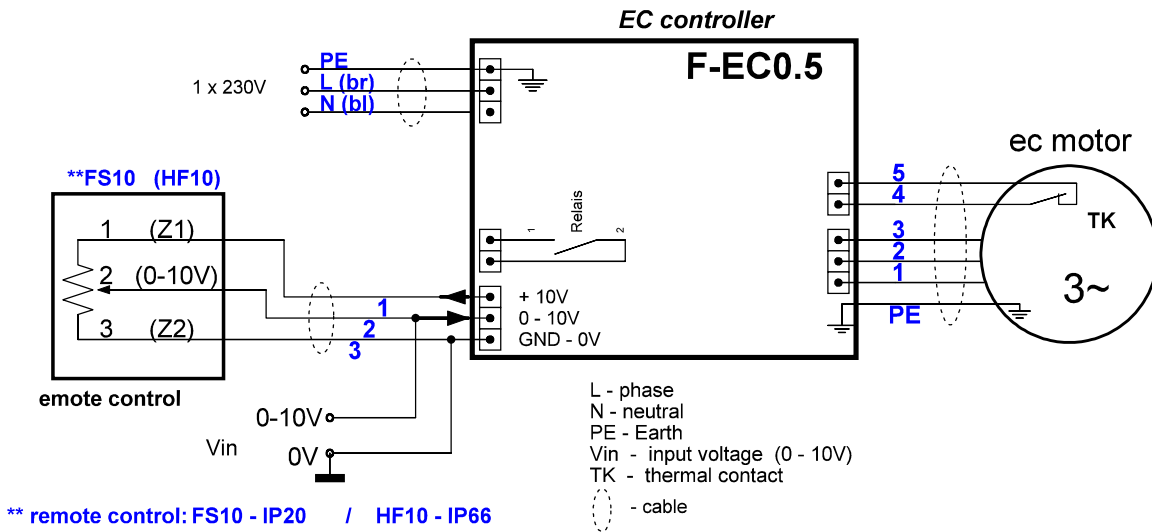

Important!!!

STOP / error reset - Vin < 1V;
START / RUN - Vin > 1V;

Operation display (2 x LED)

State	LED_RED	LED_GREEN	Description
1	ON	OFF	STOP - Vin < 1 V
2	OFF	blinkt	START - Vin > 1 V
3	OFF	ON	RUN - Vin > 1 V
4	ON blinkt	ON OFF	if RUN Vin < 1 V more than 3 seconds => Motor brakes

Error display

Error	LED_RED	LED_GREEN	Error description
1	blinkt	blinkt	motor START not possible
2	1 Impuls	OFF	motor current to high
3	2 Impulse	OFF	supply voltage to high/low
4	3 Impulse	OFF	motor temperature to high
5	4 Impulse	OFF	controller temperature to high

Error reset = Vin = 0V!!!

If fault persists, or by error repetition pls. call us!!!