

vorläufiges Datenblatt / preliminary data sheet

Series: EASY-BOX FEB
with Freewheeling impeller with
backward curved blades **EC-MOTOR**

FISCHBACH

Luft- und Ventilatorentechnik GmbH

Type: FEB450/EM850

ERP KONFORM



CE -conform

manufacturer:

Fischbach Luft- und Ventilatorentechnik GmbH
Am Hellerberg 22-24
D-57290 Neunkirchen
phone: ++49(0)2735/777-0
telefax: ++49(0)2735/770-625
internet: www.fischbach-luft.de
email: info@fischbach-luft.de

Technical Data

weight:	(kg)	35
material housing:		aluminum/plastic steel, galvanized
material impeller:		steel, galvanized
direction of rotation:		left
motor protection class:		IP 65
insulation class:		F
motor protection:		thermal contact

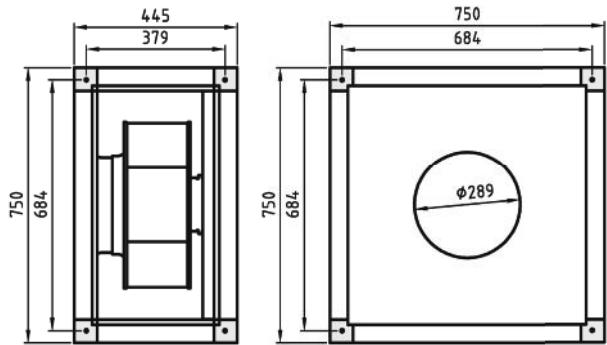

**connection plan
FFU-EC 230**

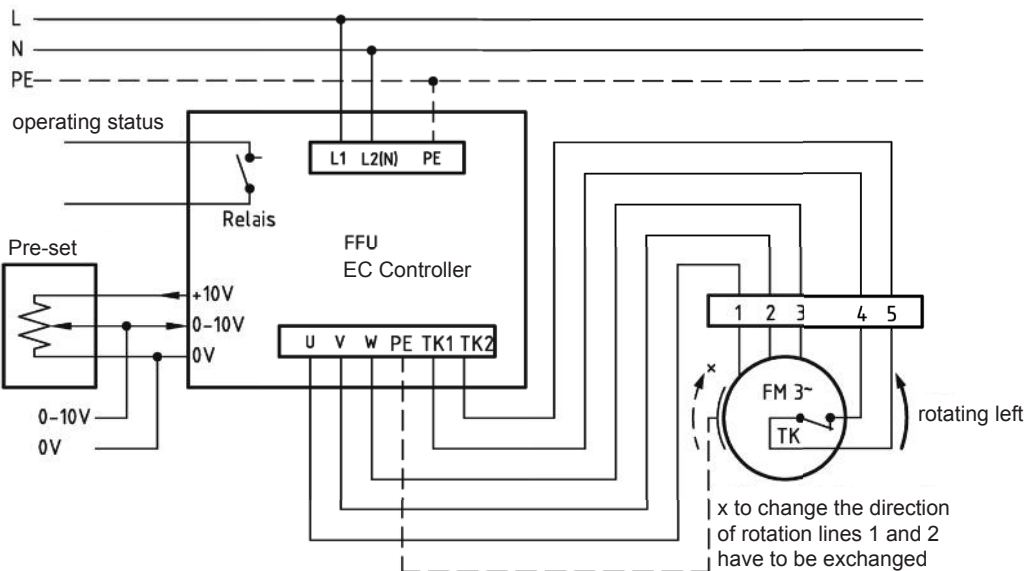

**100%
controllable**



the silent one

* Connection only according to the enclosed technical documentation.

vorläufiges Datenblatt / preliminary data sheet

Series: EASY-BOX FEB
with Freewheeling impeller with
backward curved blades **EC-MOTOR**

FISCHBACH
Luft- und Ventilatorentechnik GmbH

Type: FEB450/EM850

ErP 2013 2015 2018 x

Performance data

main voltage:	(V)	230 (1~)
frequency:	(Hz)	50
current max.:	(A)	5,7
power input max.:	(kW)	0,8
air flow volume max.:	(m³/h)	6020
statical pressure max.:	(Pa)	585
speed max.:	(rpm)	1350
max. air flow temperature	(°C)	80
max. ambient temperature	(°C)	30
capacitor:	(µF)	-

ErP-Data:

total efficiency fan (η_e):	(%)	60,8
installation category:		A
efficiency category:		static
efficiency grade: N	(%)	62
target efficiency (η_{target}):	(%)	50,3
speed controller		yes
year of manufacturing		since 2015
manufacturer: Fischbach Luft- und Ventilatorentechnik GmbH D-57290 Neunkirchen / HRB 5804 Siegen		
order no. (left)		18182630
power input:	(kW)	0,77
air flow volume:	(m³/h)	3580
statical pressure:	(Pa)	430
speed:	(rpm)	1350
specific ratio:		1
disassembling/recycling/disposal: see page decommission		
installation/operation/maintenance: see operating and mounting instructions		
measurement for determination of efficiency without additional items		

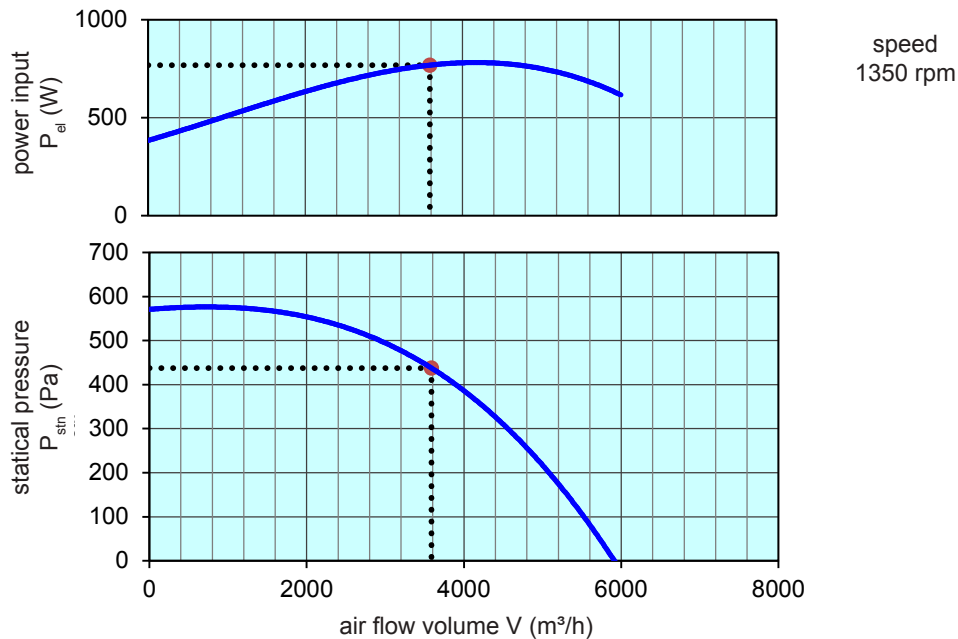

control with	type	order-Nr.
FISCHBACH-EC-controller	FFU1-21-2,2	63720
FISCHBACH-Pre-set 0-10V (optional accessories)	FS 10	69460

Technical documentation according to page: **General information**