

**Series: VENTILATION UNIT VF flat**  
with FISCHBACH COMPACT FAN  
Type CFE

**FISCHBACH**  
Luft- und Ventilatorentechnik GmbH

**Type: VF 221 CFE840/E35**

**ERP KONFORM**



**CE** -conform

**manufacturer:**  
Fischbach Luft- und Ventilatorentechnik GmbH  
Am Hellerberg 22-24  
D-57290 Neunkirchen  
phone: ++49(0)2735/777-0  
telefax: ++49(0)2735/770-625  
internet: www.fischbach-luft.de  
email: info@fischbach-luft.de

**Technical Data**

weight:	(kg)	28
material housing:	aluminum/plastic steel, galvanized	
material impeller:	steel, galvanized	
direction of rotation:	left	
motor protection class:	IP 65	
insulation class:	F	
motor protection:	thermal contact	

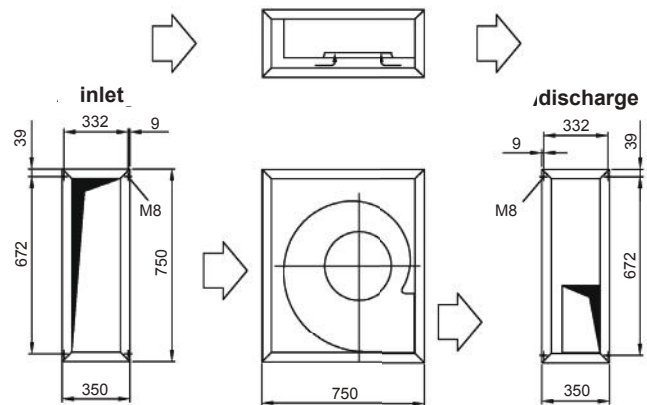

**connection plan**  
0.11-1 I.

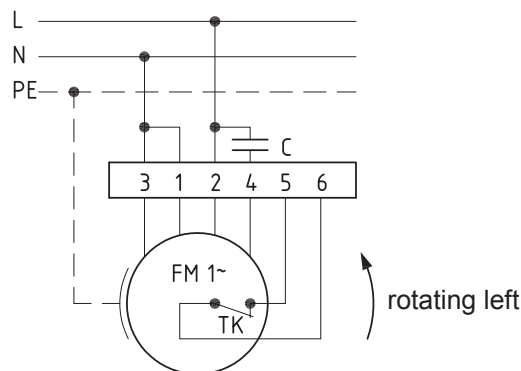

the silent one

**Type: VF 221 CFE840/E35**

Erp 2013 2015 x 2018

**Performance data**

main voltage:	(V)	230 (1~)
frequency:	(Hz)	50
current max.:	(A)	5,2
power input max.:	(kW)	1,1
air flow volume max.:	(m³/h)	2621
statical pressure max.:	(Pa)	667
speed max.:	(rpm)	1430
supply air temperature:	(°C)	-25... +60
capacitor:	(µF)	20

**ErP-Data:**

total efficiency fan ( $\eta_e$ ):	(%)	36,6
installation category:		A
efficiency category:		static
efficiency grade: N	(%)	44
target efficiency ( $\eta_{target}$ ):	(%)	36,3
speed controller		no
year of manufacturing		since 2015
manufacturer:	Fischbach Luft- und Ventilatorentechnik GmbH D-57290 Neunkirchen / HRB 5804 Siegen	
order no.:		58322110
power input:	(kW)	0,6
air flow volume:	(m³/h)	1490
statical pressure:	(Pa)	530
speed:	(rpm)	1308
specific ratio:		1

disassembling/recycling/disposal: see page decommission  
installation/operation/maintenance: see operating and mounting instructions  
measurement for determination of efficiency without additional items

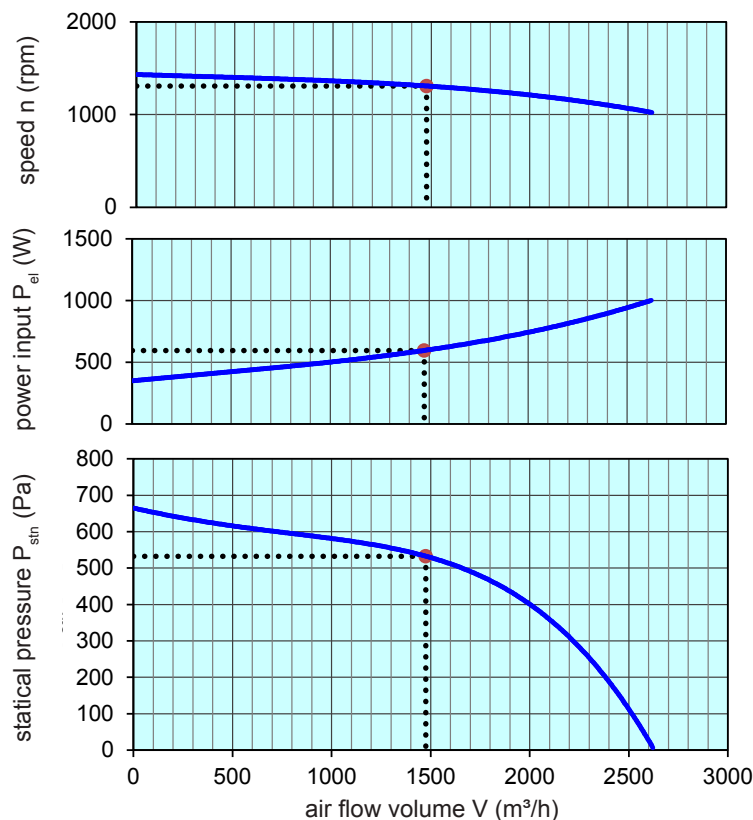

Voltage Control	type	order-no.
FISCHBACH-Speed-Controller, stepless	FDR 55	<b>6163</b>
FISCHBACH-Speed-Controller, stepwise	FDR 750	<b>6202</b>
FISCHBACH-Automatic-Control	FRA 55	<b>6252</b>
FISCHBACH-Control-Unit Frequency-Converter	FRE 6	<b>63001</b>