

Series: VENTILATION UNIT VN standard
with FISCHBACH COMPACT FAN
Type D/DS

FISCHBACH
Luft- und Ventilatorentechnik GmbH

EC-MOTOR
EC-MOTEUR

Type: VN309-EC DS9-070/DM2.5 **ERP KONFORM**



manufacturer:
Fischbach Luft- und Ventilatorentechnik GmbH
Am Hellerberg 22-24
D-57290 Neunkirchen
phone: ++49(0)2735/777-0
telefax: ++49(0)2735/770-133
internet: www.fischbach-luft.de
email: info@fischbach-luft.de

Technical Data

weight:	(kg)	127
material housing:	aluminumplastic steel/ galvanized aluminium	
material impeller:	steel, galvanized	
direction of rotation:	left	
motor protection class:	IP 65	
insulation class:	F	
motor protection:	thermal contact	

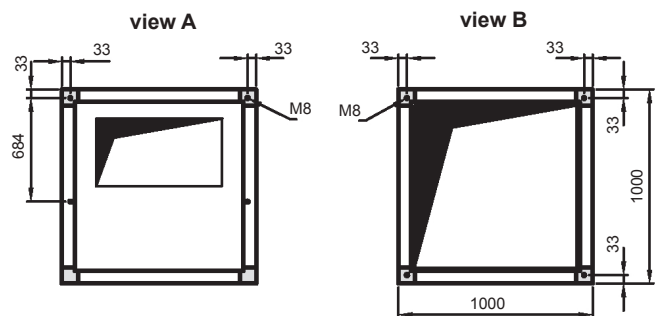
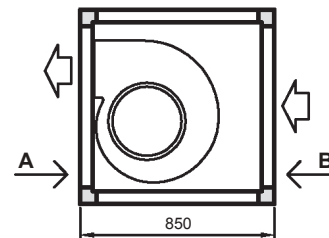

**connection plan *
FFU-EC 400**

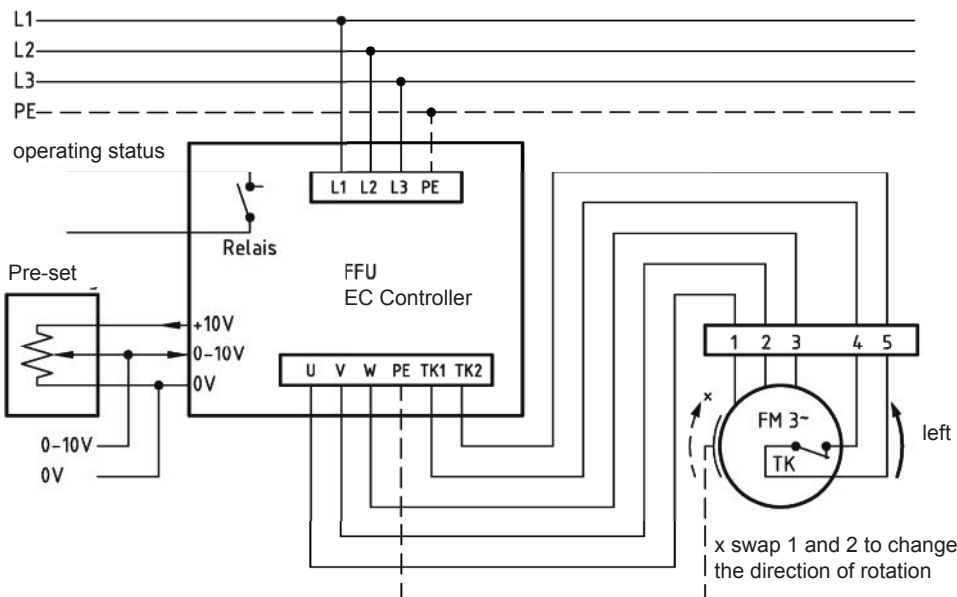

* Connection only according to the enclosed technical documentation.

the silent one



Series: VENTILATION UNIT VN standard

with FISCHBACH COMPACT FAN

Type D/DS

FISCHBACH

Luft- und Ventilatorentechnik GmbH

EC-MOTOR
EC-MOTEUR

Type: VN309-EC DS9-070/DM2.5

Erp 2013 2015 2018 x

Performance data

main voltage:	(V)	400 (3~)
frequency:	(Hz)	50
current max.:	(A)	11,6
power input max.:	(kW)	6,3
air flow volume max.:	(m³/h)	12380
statical pressure max.:	(Pa)	893
speed max.:	(rpm)	1140
supply air temperature:	(°C)	-20... +50
capacitor:	(µF)	-

ErP-Data:

total efficiency fan (η_e):	(%)	54,9
installation category:		A
efficiency category:		static
efficiency grade: N	(%)	42
target efficiency (η_{target}):	(%)	46,0
speed controller		yes
year of manufacturing		since 2015
manufacturer:	Fischbach Luft- und Ventilatorentechnik GmbH D-57290 Neunkirchen / HRB 5804 Siegen	
order no.		58832005
power input:	(kW)	1,9
air flow volume:	(m³/h)	4473
statical pressure:	(Pa)	785
speed:	(rpm)	1140
specific ratio:		1

disassembling/recycling/disposal: see page decommission
installation/operation/maintenance: see operating and mounting instructions
measurement for determination of efficiency without additional items

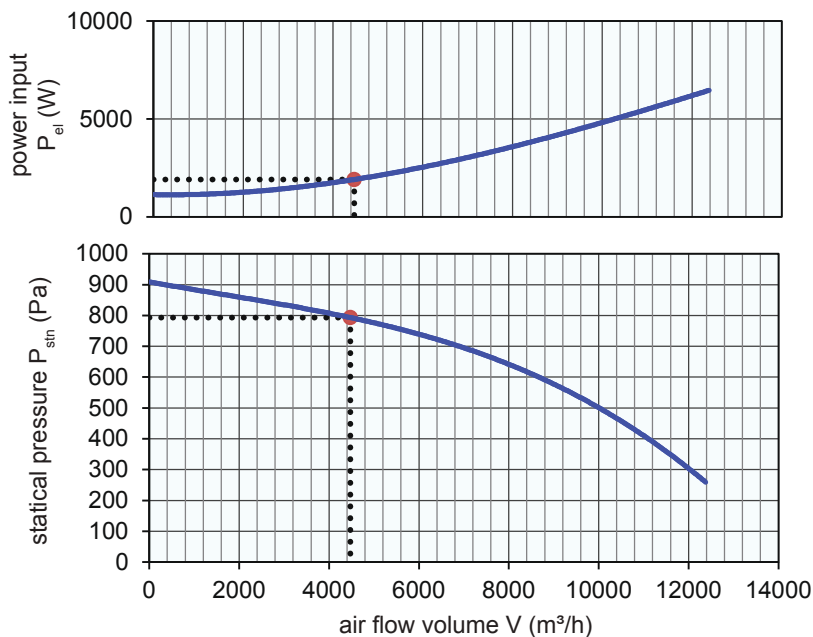

EC-controller included / accessories / sound data, please see in the appropriate table

Technical documentation according to page: **General information**