

**Series: VENTILATION UNIT VN standard**  
with FISCHBACH COMPACT FAN  
Type D/DS

**FISCHBACH**  
Luft- und Ventilatorentechnik GmbH

EC-MOTOR  
EC-MOTEUR

**Type: VN202-EC D770/DM850**

ERP KONFORM



**manufacturer:**  
Fischbach Luft- und Ventilatorentechnik GmbH  
Am Hellerberg 22-24  
D-57290 Neunkirchen  
phone: ++49(0)2735/777-0  
telefax: ++49(0)2735/770-133  
internet: www.fischbach-luft.de  
email: info@fischbach-luft.de

**Technical Data**

|                         |  |    |
|-------------------------|--|----|
| weight:                 | (kg)   | 66 |
| material housing:       | aluminumplastic steel/<br>galvanized aluminium |    |
| material impeller:      | steel, galvanized                              |    |
| direction of rotation:  | left   |    |
| motor protection class: | IP 65  |    |
| insulation class:       | F  |    |
| motor protection:       | thermal contact                                |    |

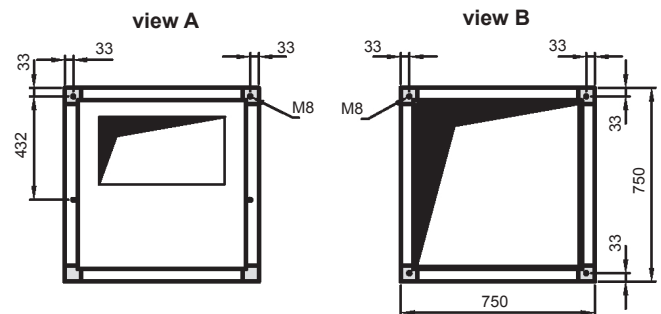
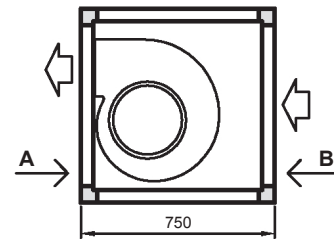

**connection plan \*  
FFU-EC 400**

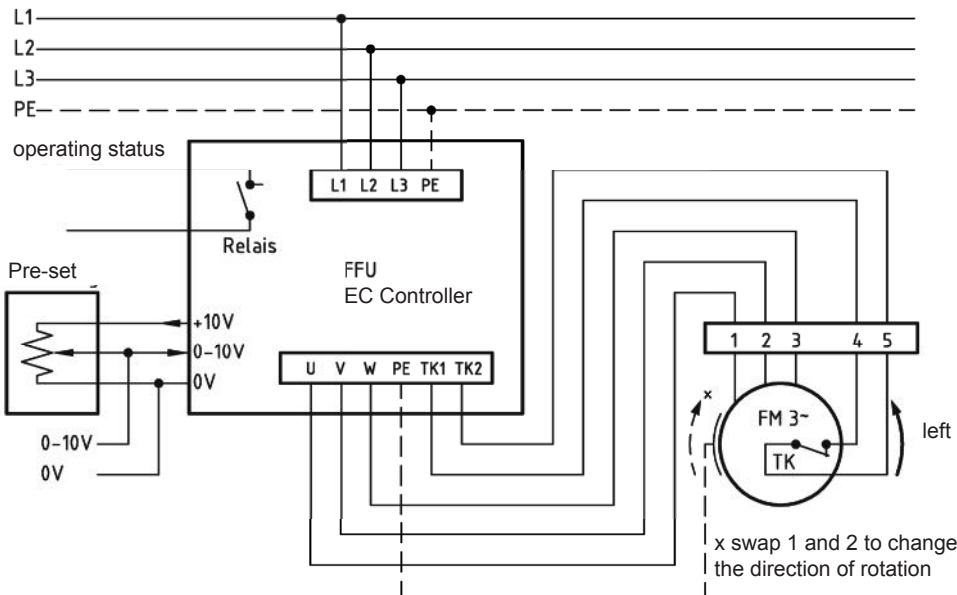

\* Connection only according to the enclosed technical documentation.

the silent one



Series: **VENTILATION UNIT VN standard**

with FISCHBACH COMPACT FAN

Type D/DS

**FISCHBACH**

Luft- und Ventilatorentechnik GmbH

EC-MOTOR  
EC-MOTEUR

## Type: VN202-EC D770/DM850

Erp 2013 2015 2018 x

### Performance data

|                         |                     |            |
|-------------------------|---------------------|------------|
| main voltage:           | (V)                 | 400 (3~)   |
| frequency:              | (Hz)                | 50         |
| current max.:           | (A)                 | 4,4        |
| power input max.:       | (kW)                | 2,0        |
| air flow volume max.:   | (m <sup>3</sup> /h) | 6500       |
| statical pressure max.: | (Pa)                | 540        |
| speed max.:             | (rpm)               | 1350       |
| supply air temperature: | (°C)                | -20... +50 |
| capacitor:              | (µF)                | -          |

### ErP-Data:

|  |   |            |
|--|---|------------|
| total efficiency fan ( $\eta_e$ ):     | (%)   | 49,4       |
| installation category:                 |   | A          |
| efficiency category:                   |   | static     |
| efficiency grade: N                    | (%)   | 42         |
| target efficiency ( $\eta_{target}$ ): | (%)   | 39,9       |
| speed controller                       |   | yes        |
| year of manufacturing                  |   | since 2015 |
| manufacturer:                          | Fischbach Luft- und Ventilatorentechnik GmbH<br>D-57290 Neunkirchen / HRB 5804 Siegen |            |
| order no.                              |   | 58822020   |
| power input:                           | (kW)  | 0,71       |
| air flow volume:                       | (m <sup>3</sup> /h)   | 2330       |
| statical pressure:                     | (Pa)  | 493        |
| speed:                                 | (rpm)   | 1350       |
| specific ratio:                        |   | 1          |

disassembling/recycling/disposal: see page decommission

installation/operation/maintenance: see operating and mounting instructions

measurement for determination of efficiency without additional items

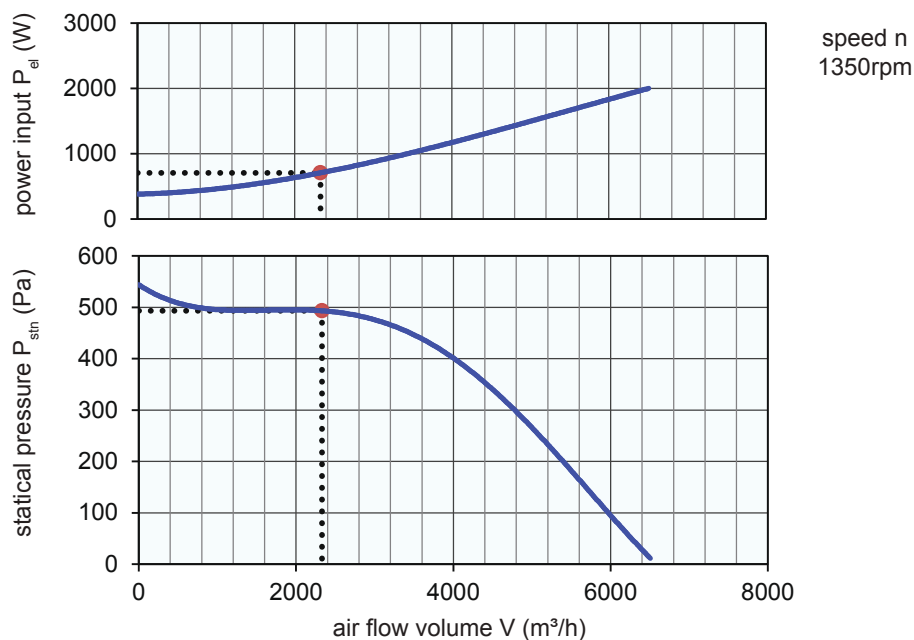

**EC-controller included / accessories / sound data**, please see in the appropriate table

Technical documentation according to page: **General information**