

Series: VENTILATION UNIT VN standard
 with FISCHBACH COMPACT FAN
 Type D/DS **EC-MOTOR**

FISCHBACH
 Luft- und Ventilatorentechnik GmbH

Type: VN101-EC D540/EM25

ERP KONFORM

CE -conform



manufacturer:
 Fischbach Luft- und Ventilatorentechnik GmbH
 Am Hellerberg 22-24
 D-57290 Neunkirchen
 phone: ++49(0)2735/777-0
 telefax: ++49(0)2735/770-625
 internet: www.fischbach-luft.de
 email: info@fischbach-luft.de

Technical Data

weight: (kg) 22
 material housing: aluminum/plastic
 steel, galvanized
 material impeller: steel, galvanized
 direction of rotation: left
 motor protection class: IP 65
 insulation class: F
 motor protection: thermal contact

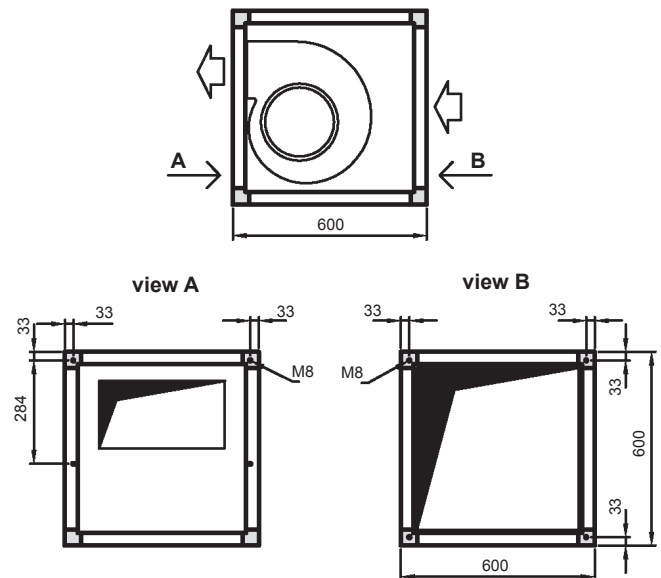

connection plan*
F-EC 0.5

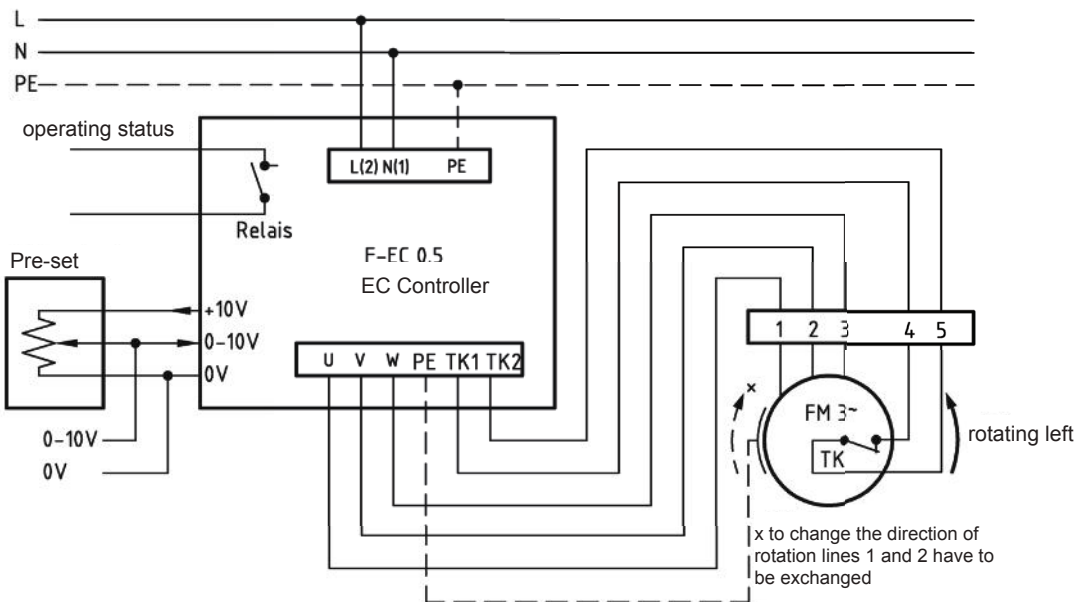

* Connection only according to the enclosed technical documentation.

the silent one

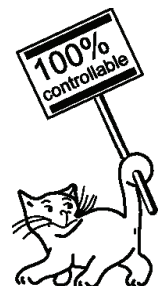

Type: VN101-EC D540/EM25

Erp 2013 2015 2018 x

Performance data

main voltage:	(V)	230 (1~)
frequency:	(Hz)	50
current max.:	(A)	3,5
power input max.:	(kW)	0,52
air flow volume max.:	(m³/h)	3010
statical pressure max.:	(Pa)	381
speed max.:	(rpm)	1365
supply air temperature:	(°C)	-25... +60
capacitor:	(µF)	-

ErP-Data:

total efficiency fan (η_e):	(%)	44,5
installation category:		A
efficiency category:		static
efficiency grade: N	(%)	42
target efficiency (η_{target}):	(%)	33,2
speed controller		yes
year of manufacturing		since 2015
manufacturer:	Fischbach Luft- und Ventilatorentechnik GmbH D-57290 Neunkirchen / HRB 5804 Siegen	
order no.:		upon request
power input:	(kW)	0,24
air flow volume:	(m³/h)	1185
statical pressure:	(Pa)	287
speed:	(rpm)	1285
specific ratio:		1
disassembling/recycling/disposal: see page decommission		
installation/operation/maintenance: see operating and mounting instructions		
measurement for determination of efficiency without additional items		

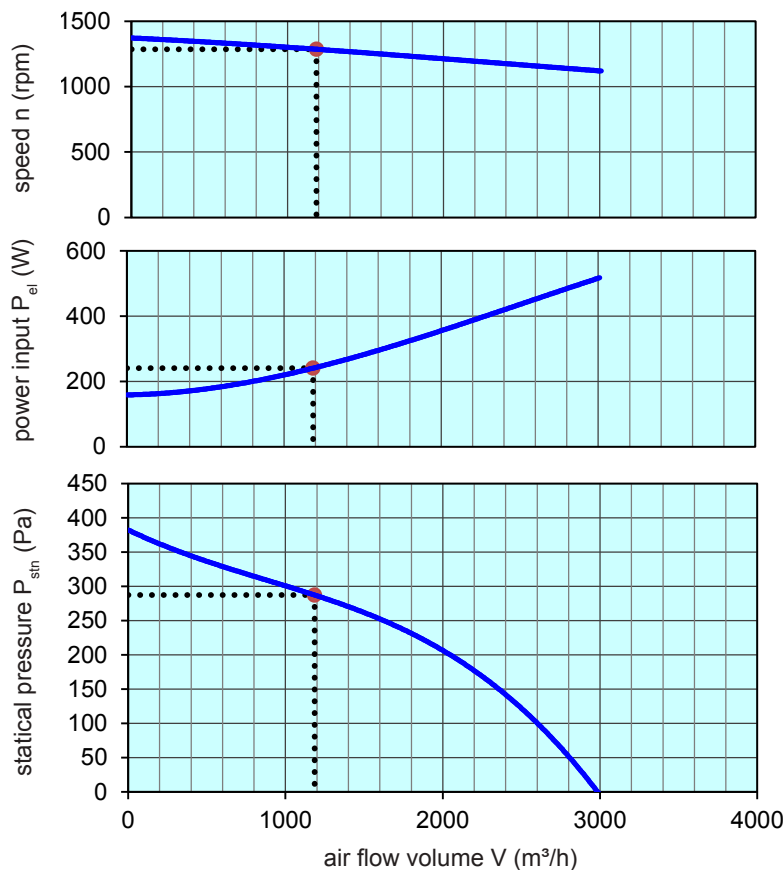

control with	type	order-Nr.
FISCHBACH-EC-controller	F-EC 0.5	63003
FISCHBACH-Pre-set 0-10V (optional accessories)	FS 10	69460

Technical documentation according to page: **General information**