

Series: VENTILATION UNIT VF flat
 with FISCHBACH COMPACT FAN
 Type CFE EC-MOTOR

FISCHBACH
 Luft- und Ventilatorentechnik GmbH

Type: VF407-EC CFE930/EM850

ERP KONFORM



CE -conform

manufacturer:
 Fischbach Luft- und Ventilatorentechnik GmbH
 Am Hellerberg 22-24
 D-57290 Neunkirchen
 phone: ++49(0)2735/777-0
 telefax: ++49(0)2735/770-625
 internet: www.fischbach-luft.de
 email: info@fischbach-luft.de

Technical Data

weight:	(kg)	45
material housing:	aluminum/plastic steel, galvanized	
material impeller:	steel, galvanized	
direction of rotation:	left	
motor protection class:	IP 65	
insulation class:	F	
motor protection:	thermal contact	

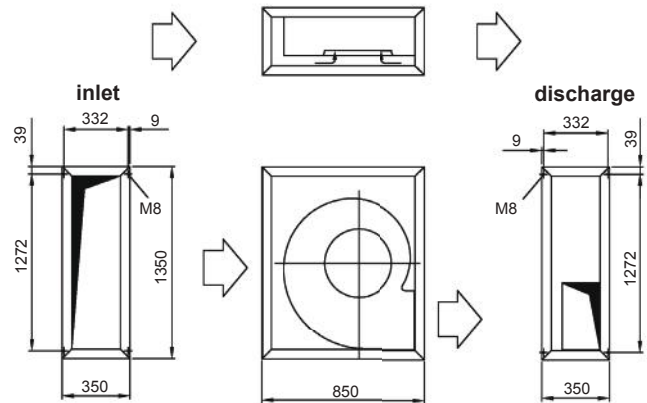

**connection plan*
 FFU-EC 230**

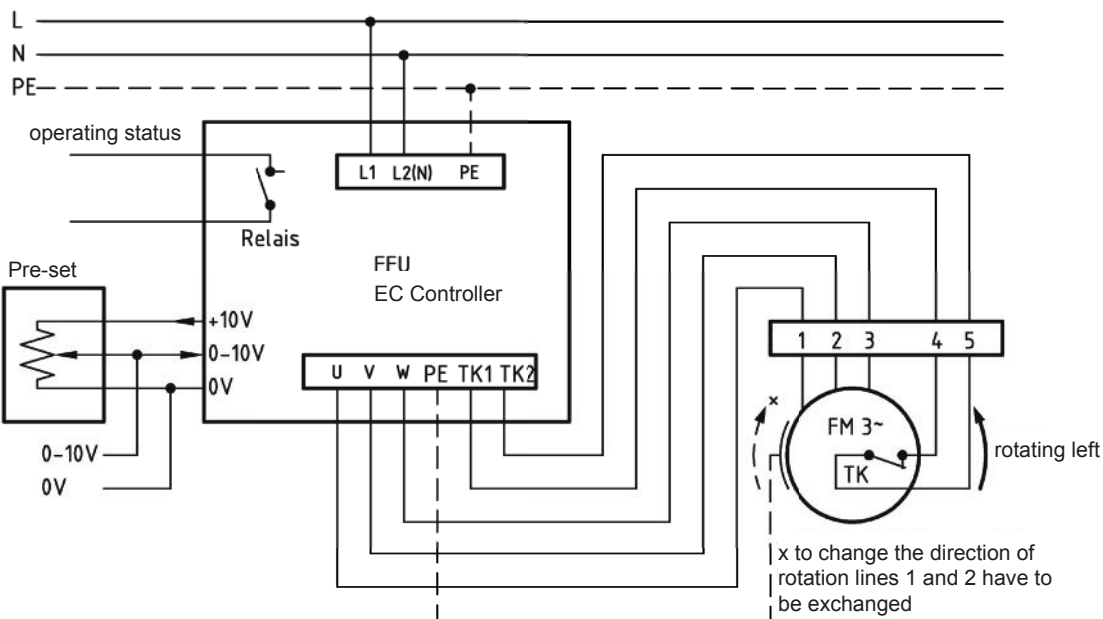

* Connection only according to the enclosed technical documentation.

the silent one



Type: VF407-EC CFE930/EM850

Erp 2013 2015 x 2018

Performance data

main voltage:	(V)	230 (1~)
frequency:	(Hz)	50
current max.:	(A)	9,6
power input max.:	(kW)	1,5
air flow volume max.:	(m³/h)	3240
statical pressure max.:	(Pa)	585
speed max.:	(rpm)	1220
supply air temperature:	(°C)	-25... +50
capacitor:	(µF)	-

ErP-Data:

total efficiency fan (η_e):	(%)	38,5
installation category:		A
efficiency category:		static
efficiency grade: N	(%)	44
target efficiency (η_{target}):	(%)	37,4
speed controller		yes
year of manufacturing		since 2015
manufacturer:	Fischbach Luft- und Ventilatorentechnik GmbH D-57290 Neunkirchen / HRB 5804 Siegen	
order no.:		upon request
power input:	(kW)	0,90
air flow volume:	(m³/h)	2115
statical pressure:	(Pa)	541
speed:	(rpm)	1220
specific ratio:		1
disassembling/recycling/disposal: see page decommission		
installation/operation/maintenance: see operating and mounting instructions		
measurement for determination of efficiency without additional items		

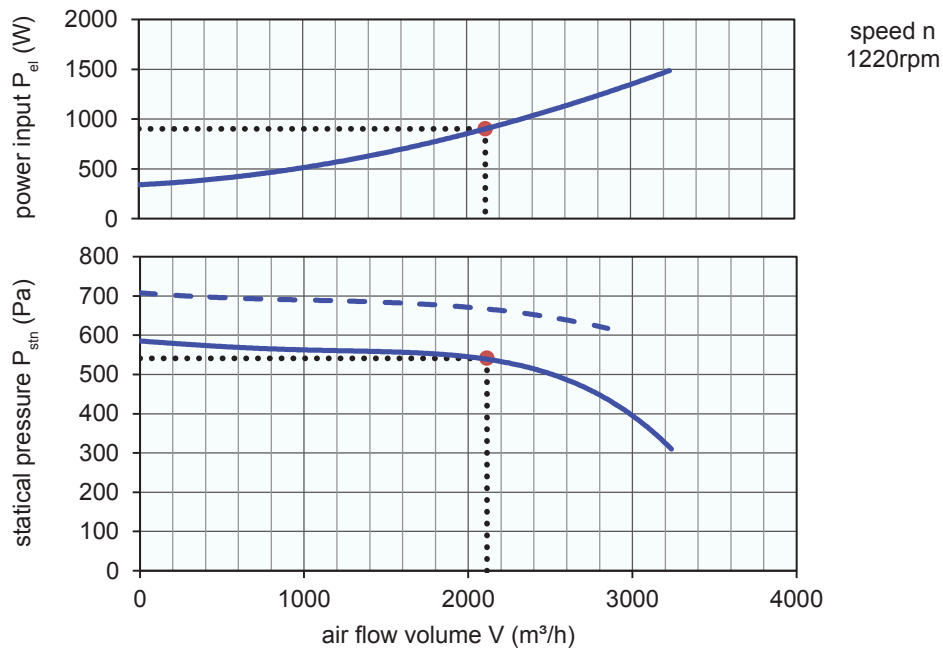

control with	type	order-Nr.
FISCHBACH-frequency-converter	FFU1-21-2.2	63720
FISCHBACH-Pre-set 0-10V (optional accessories)	FS 10	69460

Technical documentation according to page: **General information**