

**Series: VENTILATION UNIT VF flat**  
 with FISCHBACH COMPACT FAN  
 Type CFE EC-MOTOR

**FISCHBACH**

Luft- und Ventilatorentechnik GmbH

**Type: VF308-EC CFE8-940/EM850**

**ERP KONFORM**



**CE** -conform

**manufacturer:**

Fischbach Luft- und Ventilatorentechnik GmbH  
 Am Hellerberg 22-24  
 D-57290 Neunkirchen  
 phone: ++49(0)2735/777-0  
 telefax: ++49(0)2735/770-625  
 internet: www.fischbach-luft.de  
 email: info@fischbach-luft.de

**Technical Data**

weight:	(kg)	42
material housing:	aluminum/plastic steel, galvanized	
material impeller:	steel, galvanized	
direction of rotation:	left	
motor protection class:	IP 65	
insulation class:	F	
motor protection:	thermal contact	

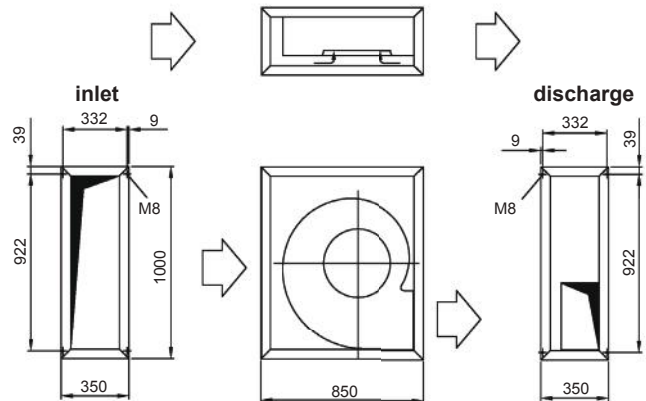

**connection plan\*  
 FFU-EC 230**

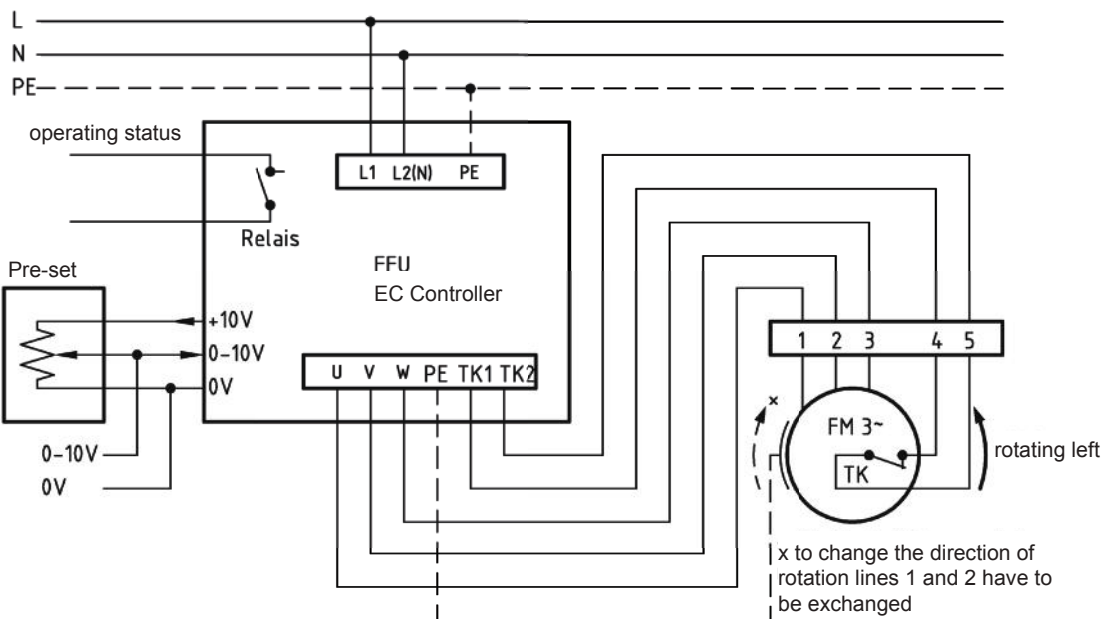

\* Connection only according to the enclosed technical documentation.

the silent one



**Type: VF308-EC CFE8-940/EM850**

Erp 2013 2015 2018 x

**Performance data**

main voltage:	(V)	230 (1~)
frequency:	(Hz)	50
current max.:	(A)	10,0
power input max.:	(kW)	1,4
air flow volume max.:	(m³/h)	3400
statical pressure max.:	(Pa)	550
speed max.:	(rpm)	1200
supply air temperature:	(°C)	-25... +50
capacitor:	(µF)	-

**ErP-Data:**

total efficiency fan ( $\eta_e$ ):	(%)	43,9
installation category:		A
efficiency category:		static
efficiency grade: N	(%)	42
target efficiency ( $\eta_{target}$ ):	(%)	39,2
speed controller		yes
year of manufacturing		since 2015
manufacturer:	Fischbach Luft- und Ventilatorentechnik GmbH D-57290 Neunkirchen / HRB 5804 Siegen	
order no.:		upon request
power input:	(kW)	0,64
air flow volume:	(m³/h)	1700
statical pressure:	(Pa)	540
speed:	(rpm)	1200
specific ratio:		1
disassembling/recycling/disposal: see page decommission		
installation/operation/maintenance: see operating and mounting instructions		
measurement for determination of efficiency without additional items		

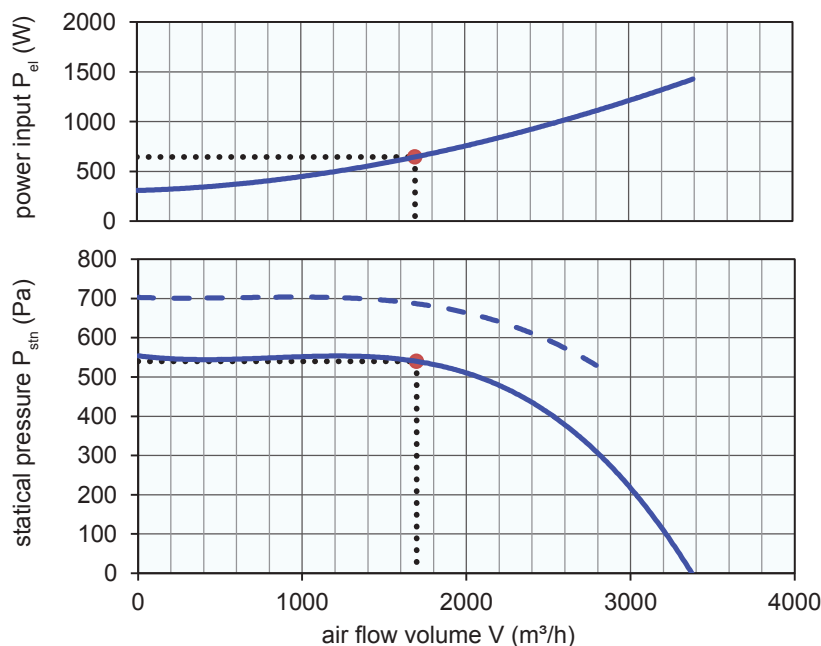

control with	type	order-Nr.
FISCHBACH-frequency-converter	FFU1-21-2.2	63720
FISCHBACH-Pre-set 0-10V (optional accessories)	FS 10	69460

Technical documentation according to page: **General information**