

**Series: VENTILATION UNIT VF flat**  
with FISCHBACH COMPACT FAN  
Type CFE

**FISCHBACH**  
Luft- und Ventilatorentechnik GmbH

EC-MOTOR  
EC-MOTEUR

**Type: VF223-EC CFE8-940/DM850** **ERP KONFORM**



**manufacturer:**  
Fischbach Luft- und Ventilatorentechnik GmbH  
Am Hellerberg 22-24  
D-57290 Neunkirchen  
phone: ++49(0)2735/777-0  
telefax: ++49(0)2735/770-133  
internet: www.fischbach-luft.de  
email: info@fischbach-luft.de

**Technical Data**

weight:	(kg)	62
material housing:	aluminumplastic steel/ galvanized aluminium	
material impeller:	steel, galvanized	
direction of rotation:	left	
motor protection class:	IP 65	
insulation class:	F	
motor protection:	thermal contact	

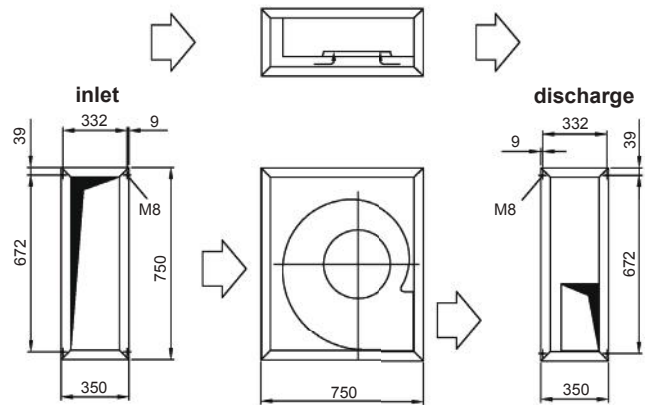

connection plan \*  
FFU-EC 400

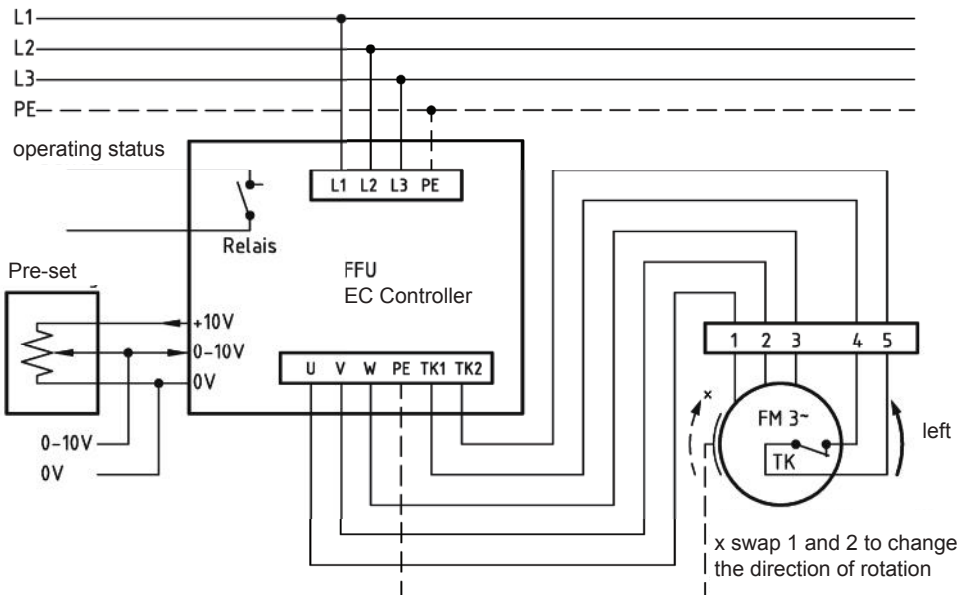

\* Connection only according to the enclosed technical documentation.

the silent one

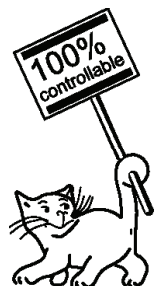

**Series: VENTILATION UNIT VF flat**  
with FISCHBACH COMPACT FAN  
Type CFE

**FISCHBACH**  
Luft- und Ventilatorentechnik GmbH

EC-MOTOR  
EC-MOTEUR

## Type: VF223-EC CFE8-940/DM850

Erp 2013 2015 2018 x

### Performance data

main voltage:	(V)	400 (3~)
frequency:	(Hz)	50
current max.:	(A)	4,6
power input max.:	(kW)	2,0
air flow volume max.:	(m³/h)	3850
statical pressure max.:	(Pa)	700
speed max.:	(rpm)	1350
supply air temperature:	(°C)	-20... +50
capacitor:	(µF)	-

### ErP-Data:

total efficiency fan ( $\eta_e$ ):	(%)	44,2
installation category:		A
efficiency category:		static
efficiency grade: N	(%)	42
target efficiency ( $\eta_{target}$ ):	(%)	41,1
speed controller		yes
year of manufacturing		since 2015
manufacturer:	Fischbach Luft- und Ventilatorentechnik GmbH D-57290 Neunkirchen / HRB 5804 Siegen	
order no.		58522140
power input:	(kW)	0,86
air flow volume:	(m³/h)	1815
statical pressure:	(Pa)	690
speed:	(rpm)	1350
specific ratio:		1

disassembling/recycling/disposal: see page decommission

installation/operation/maintenance: see operating and mounting instructions

measurement for determination of efficiency without additional items

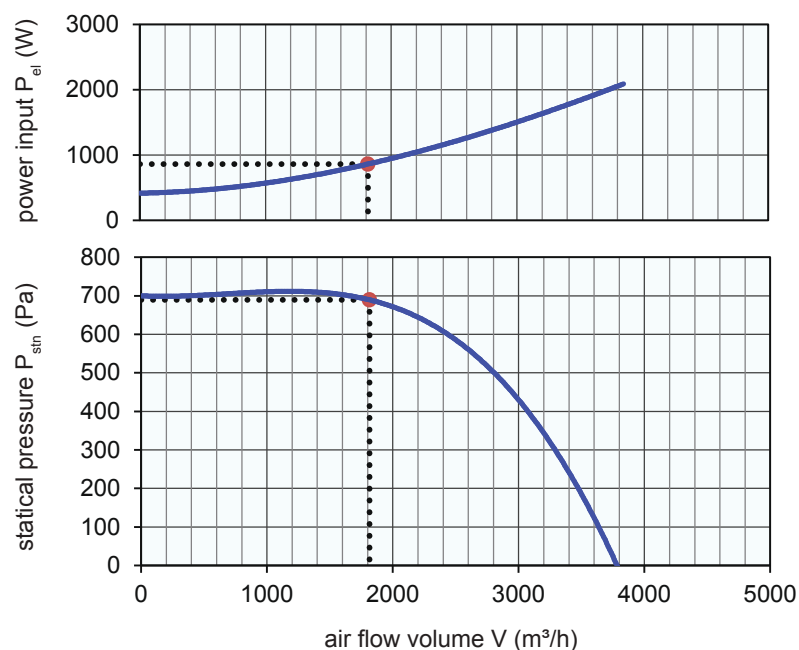

**EC-controller included / accessories / sound data**, please see in the appropriate table

Technical documentation according to page: **General information**