

**Series: ROOF TOP UNIT TYPE 41 norm**  
 with FISCHBACH COMPACT FAN  
 Type D/DS    EC-MOTOR

**FISCHBACH**  
 Luft- und Ventilatorentechnik GmbH

**Type: 41.103-EC DS6-740/EM35**    ERP KONFORM



**manufacturer:**  
 Fischbach Luft- und Ventilatorentechnik GmbH  
 Am Hellerberg 22-24  
 D-57290 Neunkirchen  
 phone:                    ++49(0)2735/777-0  
 telefax:                ++49(0)2735/770-625  
 internet:                www.fischbach-luft.de  
 email:                    info@fischbach-luft.de

**Technical Data**

weight:	(kg)	30
material housing:		aluminum/plastic steel, galvanized
material impeller:		steel, galvanized
direction of rotation:		left
motor protection class:		IP 65
insulation class:		F
motor protection:		thermal contact

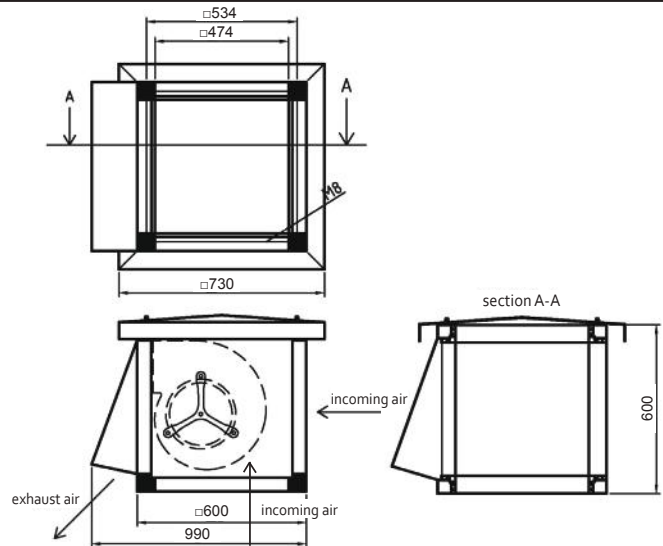

**connection plan\***  
 FFU-EC 230

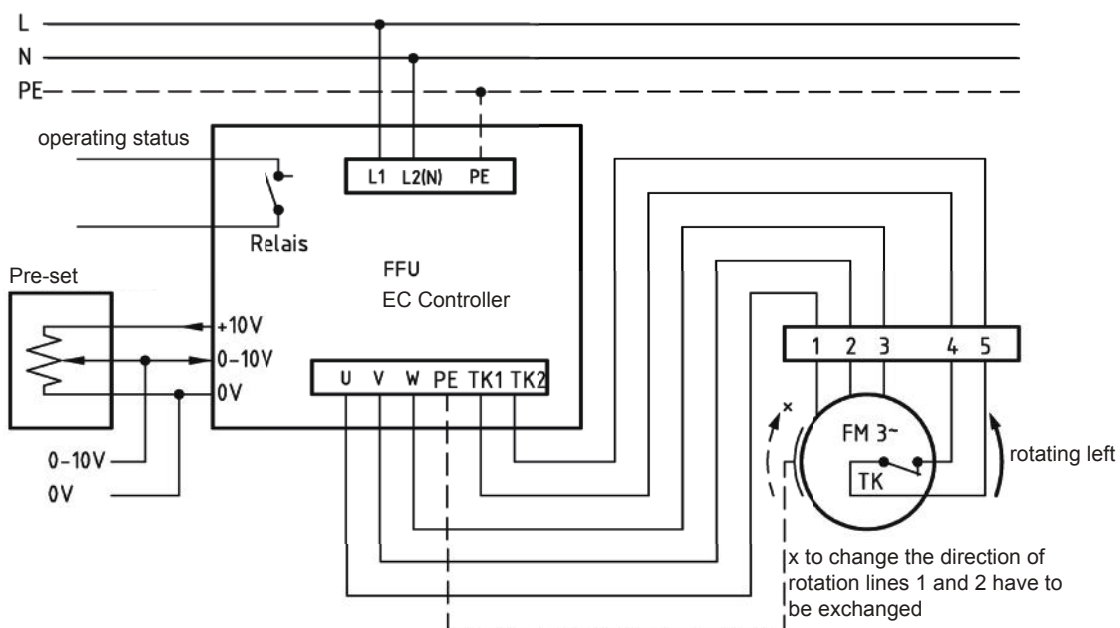

\* Connection only according to the enclosed technical documentation.

the silent one

**Series: ROOF TOP UNIT TYPE 41 norm**  
 with FISCHBACH COMPACT FAN  
 Type D/DS **EC-MOTOR**

**FISCHBACH**  
 Luft- und Ventilatorentechnik GmbH

**Type: 41.103-EC DS6-740/EM35**

Erp 2013 2015 2018 x

**Performance data**

main voltage:	(V)	230 (1~)
frequency:	(Hz)	50
current max.:	(A)	9,1
power input max.:	(kW)	1,5
air flow volume max.:	(m³/h)	4833
statical pressure max.:	(Pa)	483
speed max.:	(rpm)	1350
supply air temperature:	(°C)	-25... +60
capacitor:	(µF)	-

**ErP-Data:**

total efficiency fan ( $\eta_e$ ):	(%)	47,0
installation category:		A
efficiency category:		static
efficiency grade: N	(%)	42
target efficiency ( $\eta_{target}$ ):	(%)	39,4
speed controller		yes
year of manufacturing		since 2015
manufacturer:	Fischbach Luft- und Ventilatorentechnik GmbH D-57290 Neunkirchen / HRB 5804 Siegen	
order no.:		upon request
power input:	(kW)	0,66
air flow volume:	(m³/h)	2226
statical pressure:	(Pa)	456
speed:	(rpm)	1350
specific ratio:		1
disassembling/recycling/disposal: see page decommission		
installation/operation/maintenance: see operating and mounting instructions		
measurement for determination of efficiency without additional items		

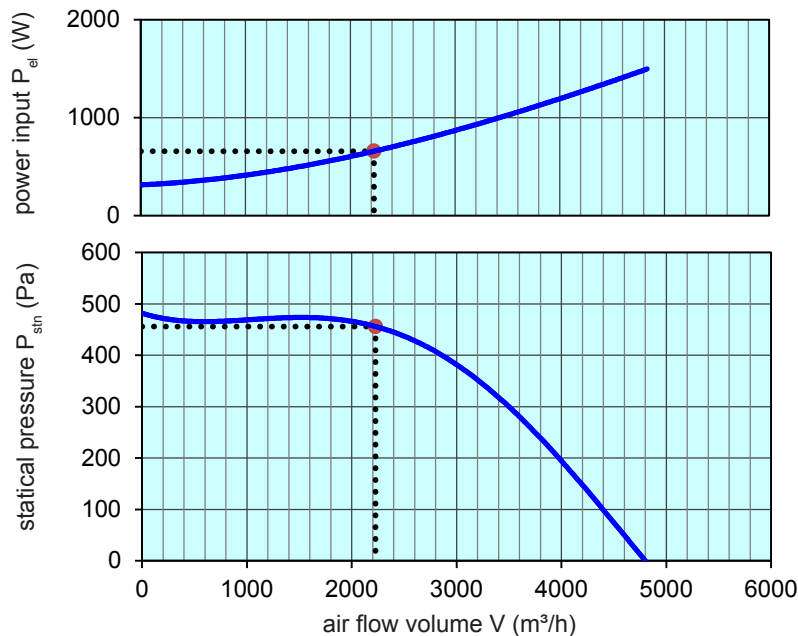

control with	type	order-Nr.
FISCHBACH-frequency-converter	FFU1-21-2.2	63720
FISCHBACH-Pre-set 0-10V (optional accessories)	FS 10	69460

Technical documentation according to page: **General information**