

Series: COMPACT-FAN Type CFE
 EC-MOTOR
 single inlet
 with forward curved blades

FISCHBACH

Luft- und Ventilatorentechnik GmbH

Type: CFE9-070/DM2

ERP KONFORM



manufacturer:

Fischbach Luft- und Ventilatorentechnik GmbH
 Am Hellerberg 22-24
 D-57290 Neunkirchen
 phone: ++49(0)2735/777-0
 telefax: ++49(0)2735/770-133
 internet: www.fischbach-luft.de
 email: info@fischbach-luft.de

Technical Data

weight:	(kg)	53
material housing:	steel, galvanized	
material impeller:	steel, galvanized	
direction of rotation:	left/right	
motor protection class:	IP 65	
insulation class:	F	
motor protection:	thermal contact	

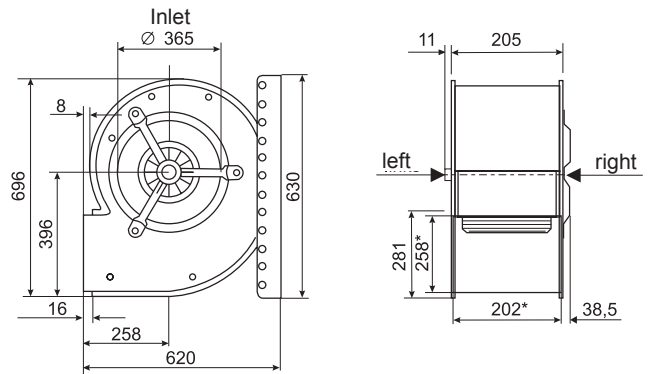

*external dimension of discharge

connection plan*
 FFU-EC 400

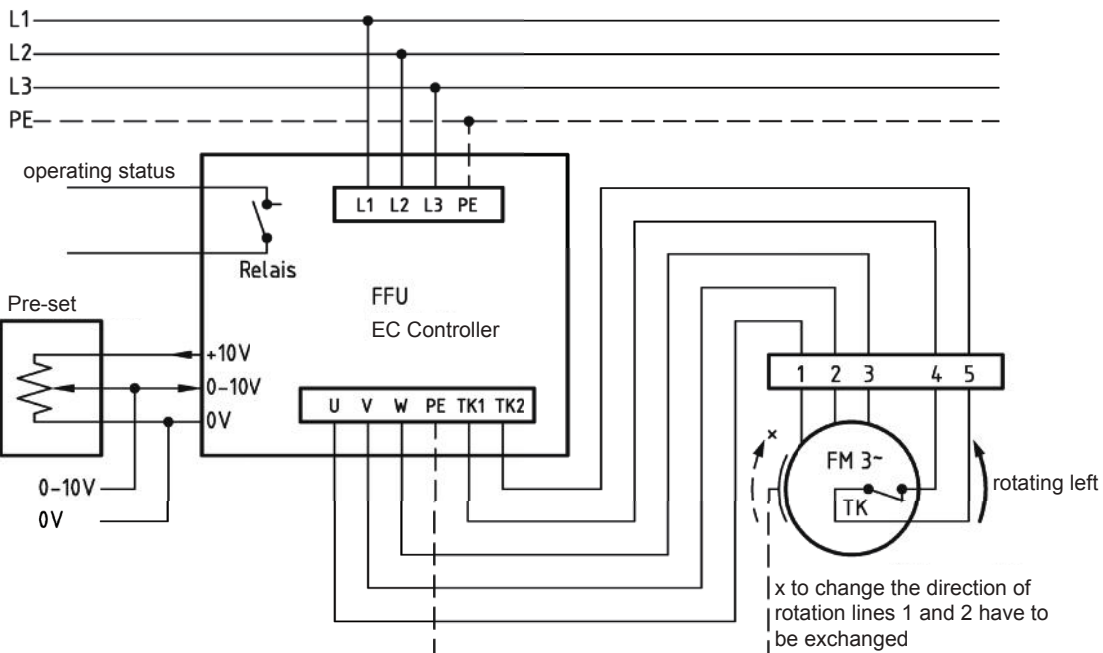

* Connection only according to the enclosed technical documentation.

the silent one



Series: COMPACT-FAN Type CFE
EC-MOTOR
 single inlet
 with forward curved blades

FISCHBACH

Luft- und Ventilatorentechnik GmbH

Type: CFE9-070/DM2

Erp 2013 2015 x 2018

Performance data

main voltage:	(V)	400 (3~)
frequency:	(Hz)	50
current max.:	(A)	6,34
power input max.:	(kW)	3,0
air flow volume max.:	(m³/h)	6060
statical pressure max.:	(Pa)	787
speed max.:	(rpm)	1200
supply air temperature:	(°C)	-25... +45
capacitor:	(µF)	-

ErP-Data:

total efficiency fan (η_e):	(%)	41,8
installation category:		A
efficiency category:		static
efficiency grade: N	(%)	44
target efficiency (η_{target}):	(%)	38,5
speed controller		yes
year of manufacturing		since 2015
manufacturer:	Fischbach Luft- und Ventilatorentechnik GmbH D-57290 Neunkirchen / HRB 5804 Siegen	
order no. (left/right)		18121670/18121870
power input:	(kW)	1,35
air flow volume:	(m³/h)	2755
statical pressure:	(Pa)	683
speed:	(rpm)	1200
specific ratio:		1
disassembling/recycling/disposal: see page decommission		
installation/operation/maintenance: see operating and mounting instructions		
measurement for determination of efficiency without additional items		

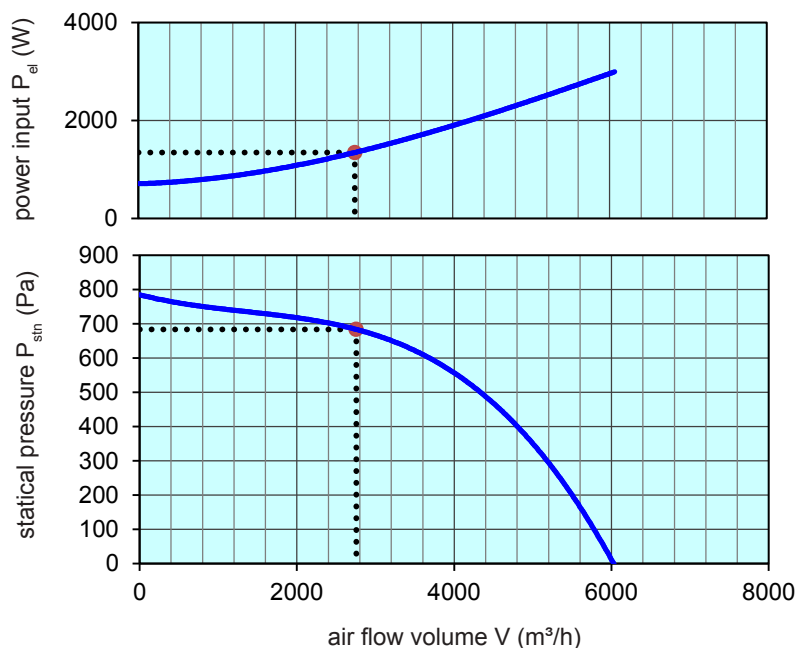

control with	type	order-Nr.
FISCHBACH-frequency-converter	FFU3-21-5,5	63765
FISCHBACH-Pre-set 0-10V (optional accessories)	FS 10	69460

Technical documentation according to page: **General information**