

Series: COMPACT-FAN Type CFE

single inlet
with forward curved blades

FISCHBACH

Luft- und Ventilatorentechnik GmbH

EC-MOTOR
EC-MOTEUR

Type: CFE8-940/DM850

ERP KONFORM

CE -conform

UK
CA



manufacturer:

Fischbach Luft- und Ventilatorentechnik GmbH
Am Hellerberg 22-24
D-57290 Neunkirchen
phone: ++49(0)2735/777-0
telefax: ++49(0)2735/770-133
internet: www.fischbach-luft.de
email: info@fischbach-luft.de

++49(0)2735/777-0
++49(0)2735/770-133
www.fischbach-luft.de
info@fischbach-luft.de

Technical Data

weight:	(kg)	30
material housing:	steel, galvanized	
material impeller:	steel, galvanized	
direction of rotation:	left/right	
motor protection class:	IP 65	
insulation class:	F	
motor protection:	thermal contact	

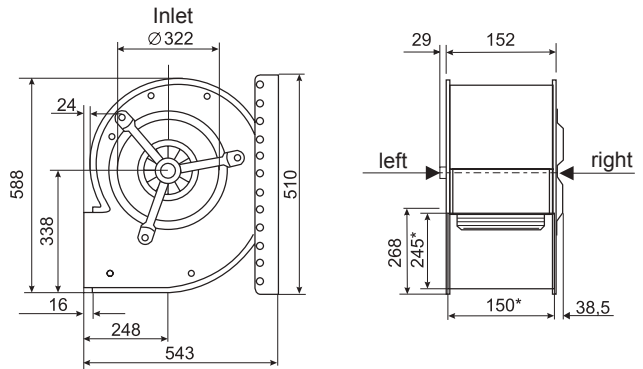

*external dimension of discharge

**connection plan*
FFU-EC 400**

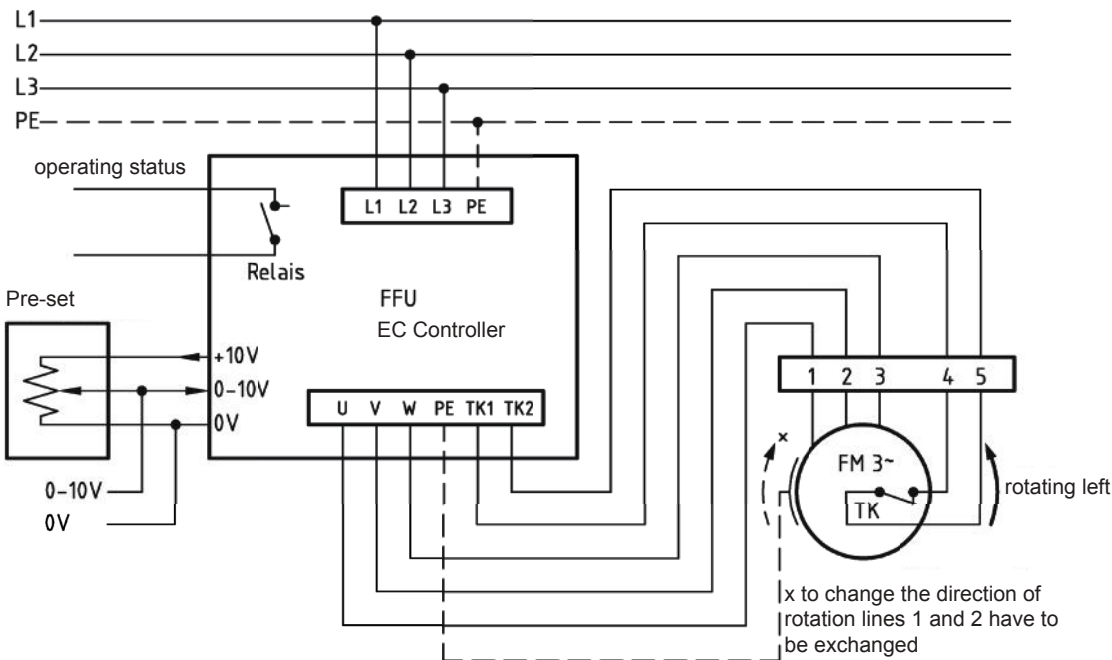

* Connection only according to the enclosed technical documentation.

the silent one



Series: COMPACT-FAN Type CFE

single inlet
with forward curved blades

FISCHBACH

Luft- und Ventilatorentechnik GmbH

EC-MOTOR
EC-MOTEUR

Type: CFE8-940/DM850

Erp 2013 2015 2018 x

Performance data

main voltage:	(V)	400 (3~)
frequency:	(Hz)	50
current max.:	(A)	4,6
power input max.:	(kW)	2,0
air flow volume max.:	(m³/h)	3850
statical pressure max.:	(Pa)	700
speed max.:	(rpm)	1350
supply air temperature:	(°C)	-20...+50
capacitor:	(µF)	-

ErP-Data:

total efficiency fan (η_e):	(%)	44,2
installation category:		A
efficiency category:		static
efficiency grade: N	(%)	42
target efficiency (η_{target}):	(%)	41,1
speed controller		yes
year of manufacturing		since 2015
manufacturer:	Fischbach Luft- und Ventilatorentechnik GmbH D-57290 Neunkirchen / HRB 5804 Siegen	
order no. le/ri		18121720/18121920
power input:	(kW)	0,86
air flow volume:	(m³/h)	1815
statical pressure:	(Pa)	690
speed:	(rpm)	1350
specific ratio:		1

disassembling/recycling/disposal: see page decommission

installation/operation/maintenance: see operating and mounting instructions

measurement for determination of efficiency without additional items

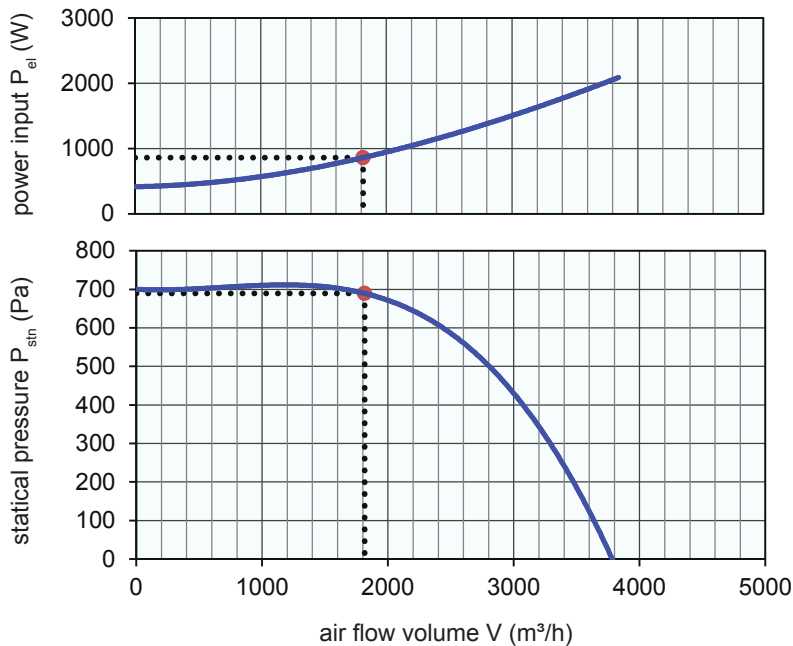

EC-controller included / accessories / sound data, please see in the appropriate table

Technical documentation according to page: **General information**