

**Series: MULTI-EXHAUST-UNIT FMB**  
 with Freewheeling impeller with  
 backward curved blades **EC-MOTOR**

**FISCHBACH**

Luft- und Ventilatorentechnik GmbH

**Type: FMB3/2-630/DM2**

**ERP KONFORM**



**manufacturer:**

Fischbach Luft- und Ventilatorentechnik GmbH  
 Am Hellerberg 22-24  
 D-57290 Neunkirchen  
 phone:  
 telefax:  
 internet:  
 email:

++49(0)2735/777-0  
 ++49(0)2735/770-133  
 www.fischbach-luft.de  
 info@fischbach-luft.de

**Technical Data**

weight:	(kg)	72
material housing:	aluminum/plastic	
	steel, galvanized	
material impeller:	steel, galvanized	
direction of rotation:	left/right	
motor-protection class:	IP 65	
insulation class:	F	
motor protection:	thermal contact	

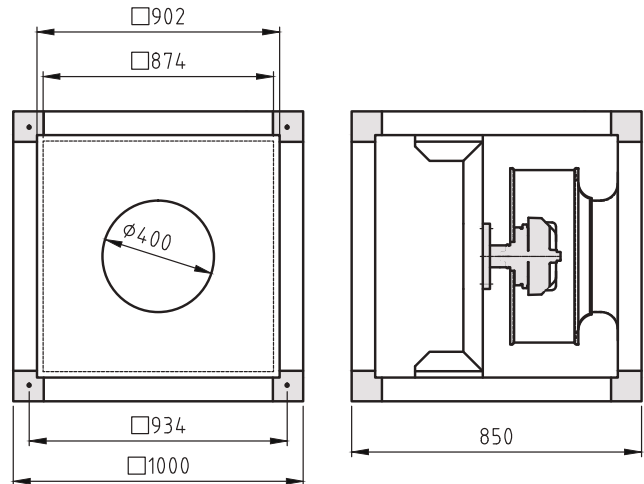

**connection plan\***  
**FFU-EC 400**

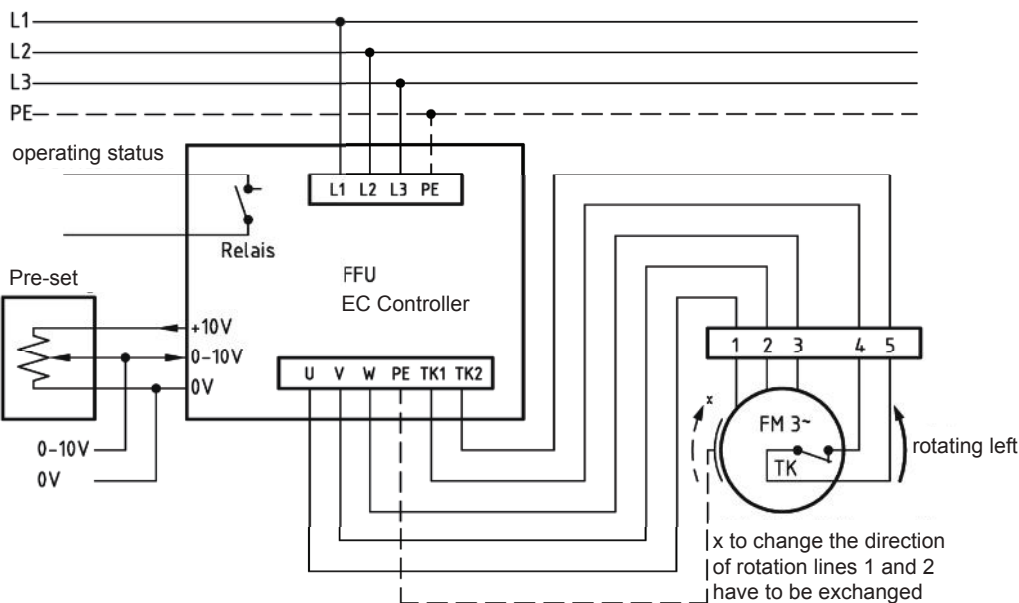

\* Connection only according to the enclosed technical documentation.

the silent one



**Series: MULTI-EXHAUST-UNIT FMB**  
 with Freewheeling impeller with  
 backward curved blades **EC-MOTOR**

**FISCHBACH**  
 Luft- und Ventilatorentechnik GmbH

**Type: FMB3/2-630/DM2**

Erp 2013 2015 2018 x

**Performance data**

main voltage:	(V)	400 (3~)
frequency:	(Hz)	50
current max.:	(A)	7,7
power input max.:	(kW)	3,82
air flow volume max.:	(m³/h)	15425
statical pressure max.:	(Pa)	1010
speed max.:	(rpm)	1350
supply air temperature:	(°C)	-25... +45
capacitor:	(µF)	-

**ErP-Data:**

total efficiency fan ( $\eta_e$ ):	(%)	60,3
installation category:		A
efficiency category:		static
efficiency grade: N	(%)	62
target efficiency ( $\eta_{target}$ ):	(%)	57,5
speed controller		yes
year of manufacturing		since 2015
manufacturer:	Fischbach Luft- und Ventilatorentechnik GmbH D-57290 Neunkirchen / HRB 5804 Siegen	
order no. (left)		18125070
power input:	(kW)	3,75
air flow volume:	(m³/h)	9323
statical pressure:	(Pa)	833
speed:	(rpm)	1350
specific ratio:		1
disassembling/recycling/disposal: see page decommission		
installation/operation/maintenance: see operating and mounting instructions		
measurement for determination of efficiency without additional items		

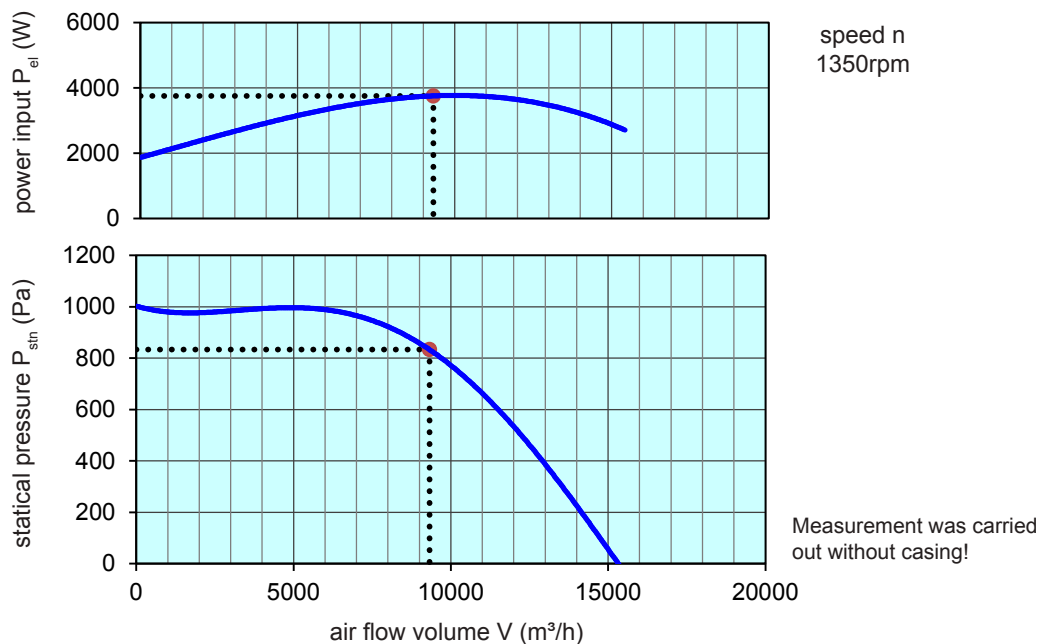

control with	type	order-Nr.
FISCHBACH-frequency-converter	FFU3-21-5,5	63765
FISCHBACH-Pre-set 0-10V (optional accessories)	FS 10	69460

Technical documentation according to page: **General information**