

Series: MULTI-EXHAUST-UNIT FMB
 with Freewheeling impeller with
 backward curved blades **EC-MOTOR**

FISCHBACH

Luft- und Ventilatorentechnik GmbH

Type: FMB2/4-500/DM1

ErP KONFORM



CE -conform

manufacturer:

Fischbach Luft- und Ventilatorentechnik GmbH
 Am Hellerberg 22-24
 D-57290 Neunkirchen
 phone: ++49(0)2735/777-0
 telefax: ++49(0)2735/770-625
 internet: www.fischbach-luft.de
 email: info@fischbach-luft.de

Technical Data

weight:	(kg)	42
material housing:		aluminum/plastic steel, galvanized
material impeller:		steel, galvanized
direction of rotation:		left/right
motor-protection class:		IP 65
insulation class:		F
motor protection:		thermal contact

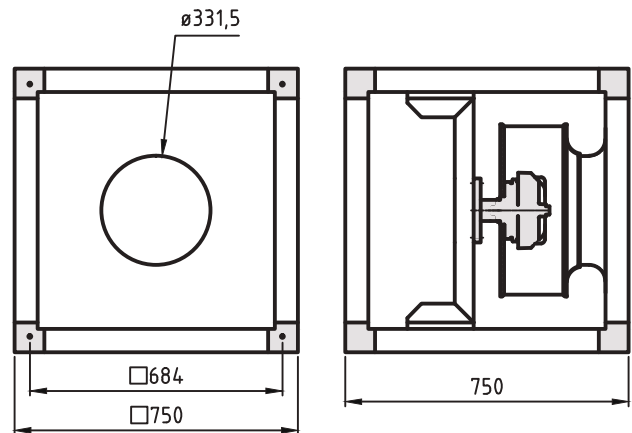

connection plan*
FFU-EC 400

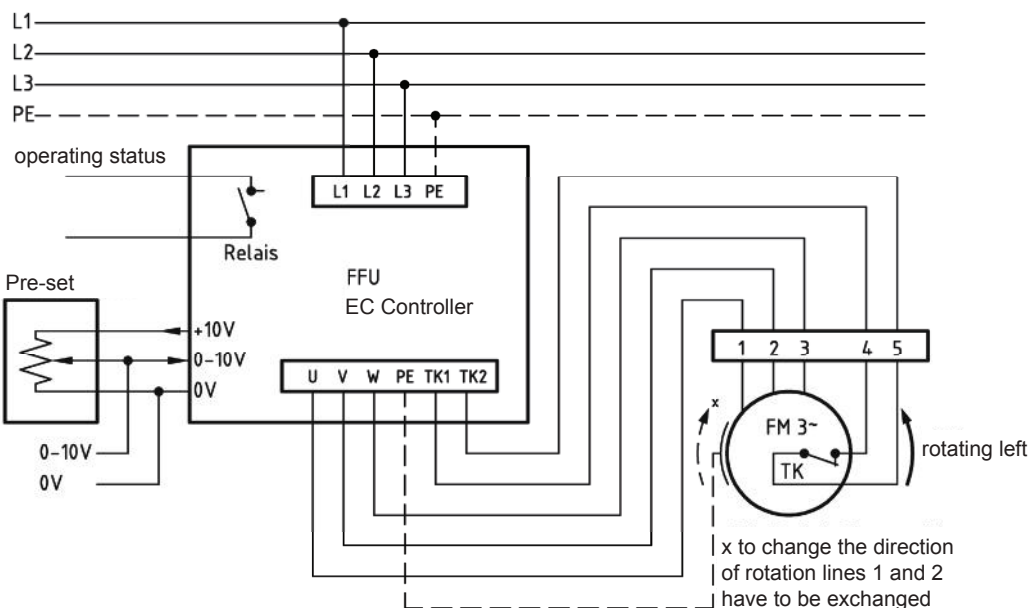

* Connection only according to the enclosed technical documentation.

the silent one

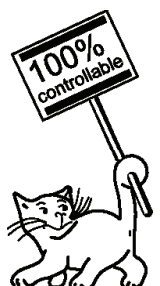

Series: MULTI-EXHAUST-UNIT FMB
 with Freewheeling impeller with
 backward curved blades **EC-MOTOR**

FISCHBACH
 Luft- und Ventilatorentechnik GmbH

Type: FMB2/4-500/DM1

Erp 2013 2015 2018 x

Performance data

main voltage:	(V)	400 (3~)
frequency:	(Hz)	50
current max.:	(A)	3,7
power input max.:	(kW)	1,7
air flow volume max.:	(m³/h)	8700
statical pressure max.:	(Pa)	777
speed max.:	(rpm)	1500
supply air temperature:	(°C)	-25... +50
capacitor:	(µF)	-

ErP-Data:

total efficiency fan (η_e):	(%)	58,4
installation category:		A
efficiency category:		static
efficiency grade: N	(%)	62
target efficiency (η_{target}):	(%)	53,8
speed controller		yes
year of manufacturing		since 2015
manufacturer: Fischbach Luft- und Ventilatorentechnik GmbH D-57290 Neunkirchen / HRB 5804 Siegen		
order no. (left)		18125050
power input:	(kW)	1,67
air flow volume:	(m³/h)	5648
statical pressure:	(Pa)	580
speed:	(rpm)	1500
specific ratio:		1
disassembling/recycling/disposal: see page decommission		
installation/operation/maintenance: see operating and mounting instructions		
measurement for determination of efficiency without additional items		

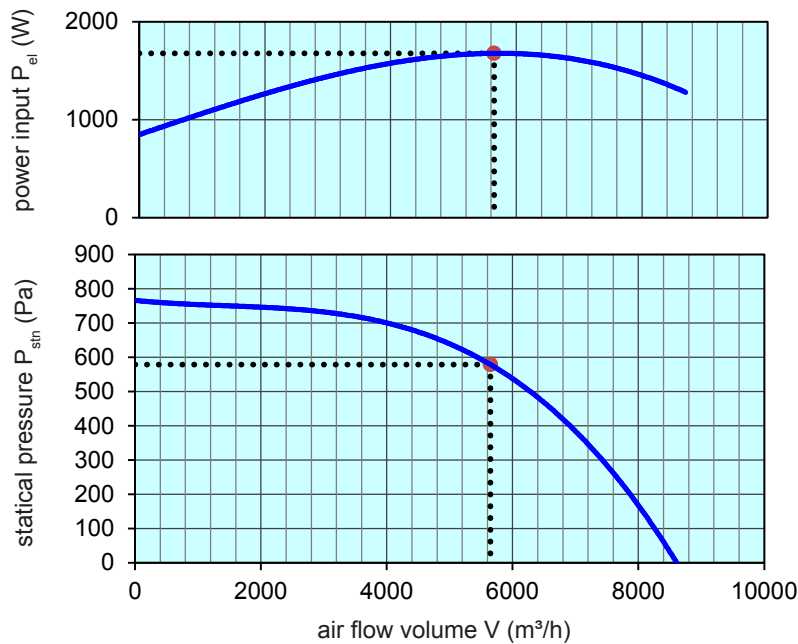

control with	type	order-Nr.
FISCHBACH-frequency-converter	FFU3-21-4	63760
FISCHBACH-Pre-set 0-10V (optional accessories)	FS 10	69460

Technical documentation according to page: **General information**